

CASH ACME®
BACKFLOW PREVENTERS
MODELS DC100/500, RP 100/200/500, & PVB
Operation & Maintenance Manual

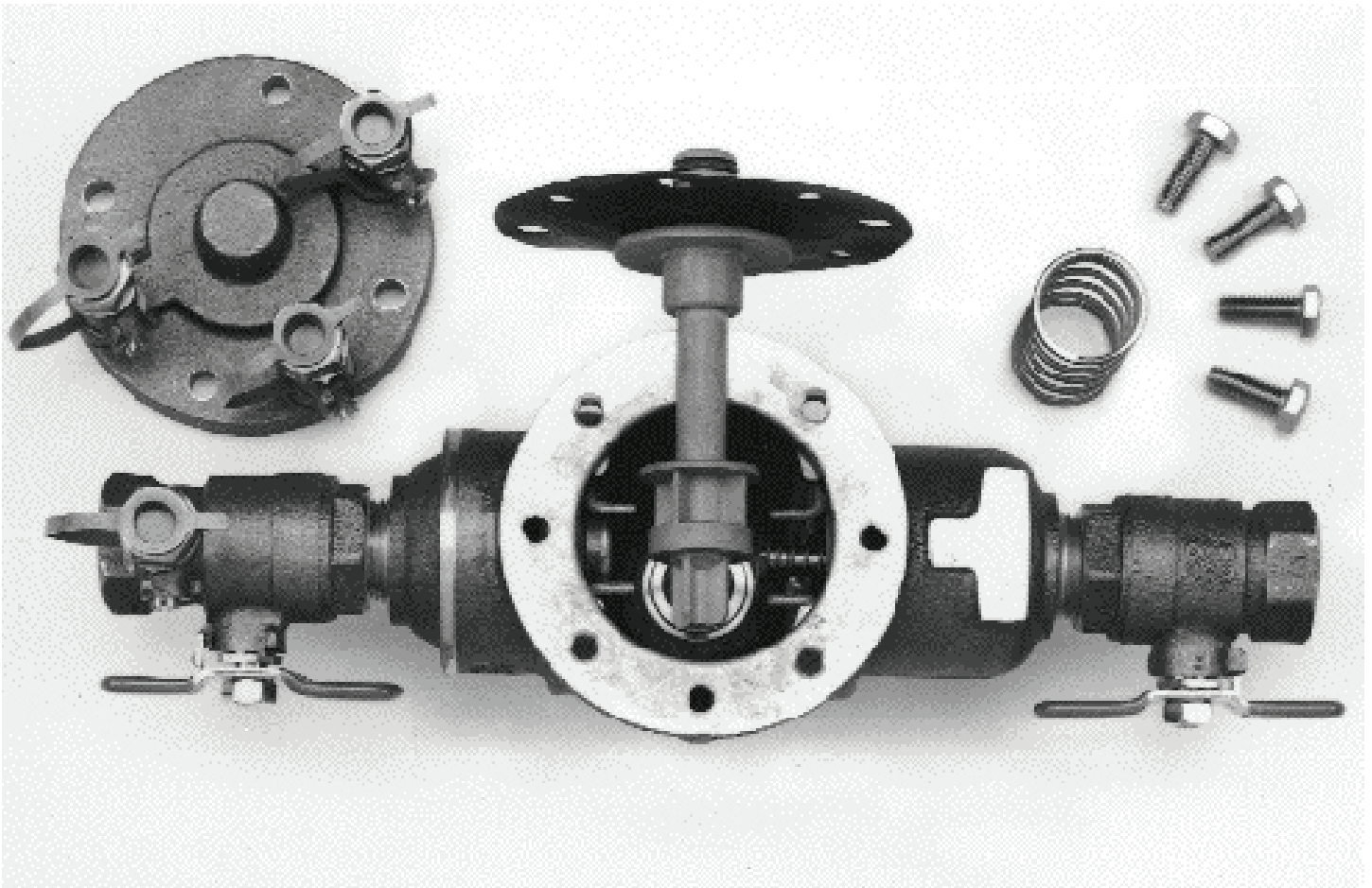

OVERBUILT IS AN UNDERSTATEMENT.®

A Division of the Reliance Worldwide Corporation 

Operating & Maintenance Procedures	3
Specification Sheet RP 1/2" - 2"	4
Installation Guidelines & Procedures	5
Trouble Shooting Guide	6
Trouble Shooting Procedures	7
Service Procedures for RP & DC	8
Check Valve Service Procedures	9
Relief Valve Service Procedures	10
Pressure Vacuum Breaker	12
Repair kits for PVB	13
Repair kits	14
Backflow Preventers	15
Selection Guide	20
Policies & Warranty	21



OVERBUILT IS AN UNDERSTATEMENT.®

REDUCED PRESSURE BACKFLOW PREVENTERS

Cash Acme® has a consistent backflow design that ranges from 1/2" -10", (15mm-250mm). The Cash Acme Model RP design is a more compact/economical model and is used when space is limited. The Cash Acme Model RP 100/200 is available in size 1/2" - 2" (19mm-50mm) with a bronze body and cover as standard. The 2-1/2" -10", (64mm-250mm) are manufactured with epoxy coated ductile iron for strength. Model RP500 is the no-lead model.

The Cash Acme backflow preventer includes tightly closing resilient seated shut-off valves on each end of the body. The assembly has two independent and internally loaded check valves with a pressure differential relief valve between them.

The pressure drop across the first check valve is approximately 6.0 PSID (41 kPa). The relief valve consists of a hydraulically balanced diaphragm. The high-pressure side of the first check valve is connected to the top of the diaphragm through an access hole in the body of the casting. The low-pressure side is connected to the reduced pressure zone keeping the relief valve closed during normal operation. Relief valve is spring loaded to force the relief valve open when the pressure drop across the first check reduces to approximately 2.5 PSID (17 kPa).

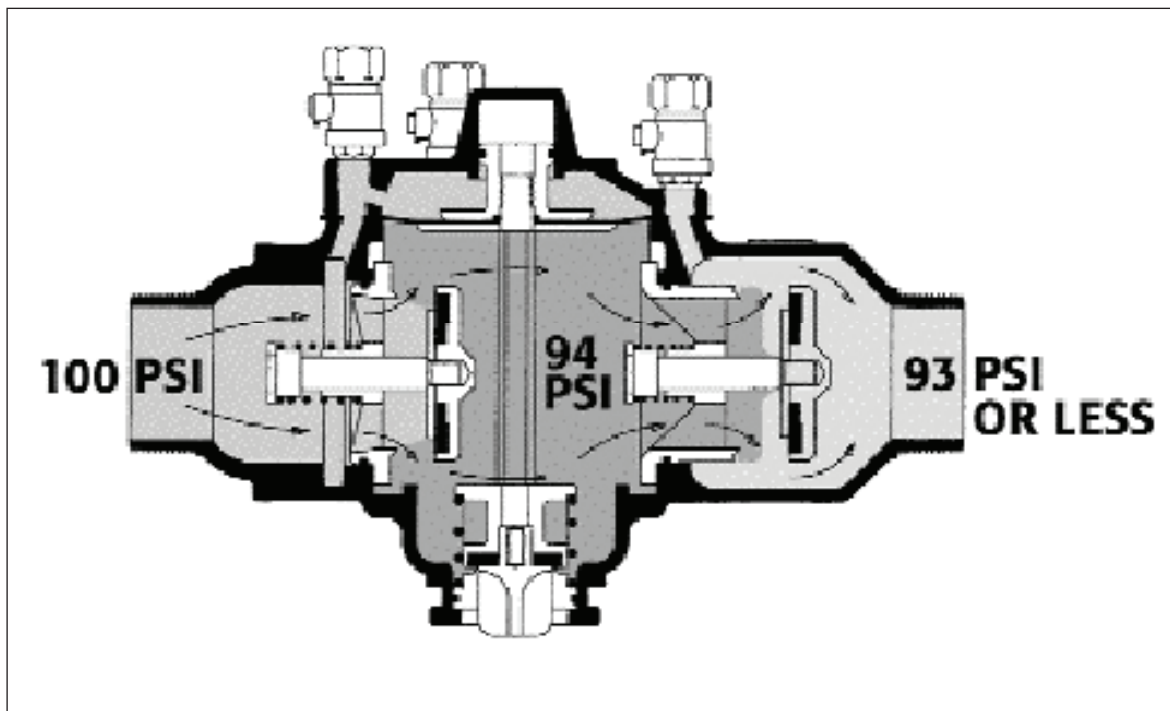

Flow Direction

NORMAL FLOW CONDITION

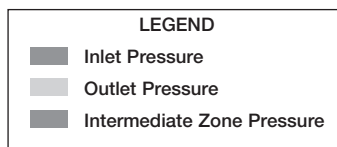

OVERBUILT IS AN UNDERSTATEMENT.®

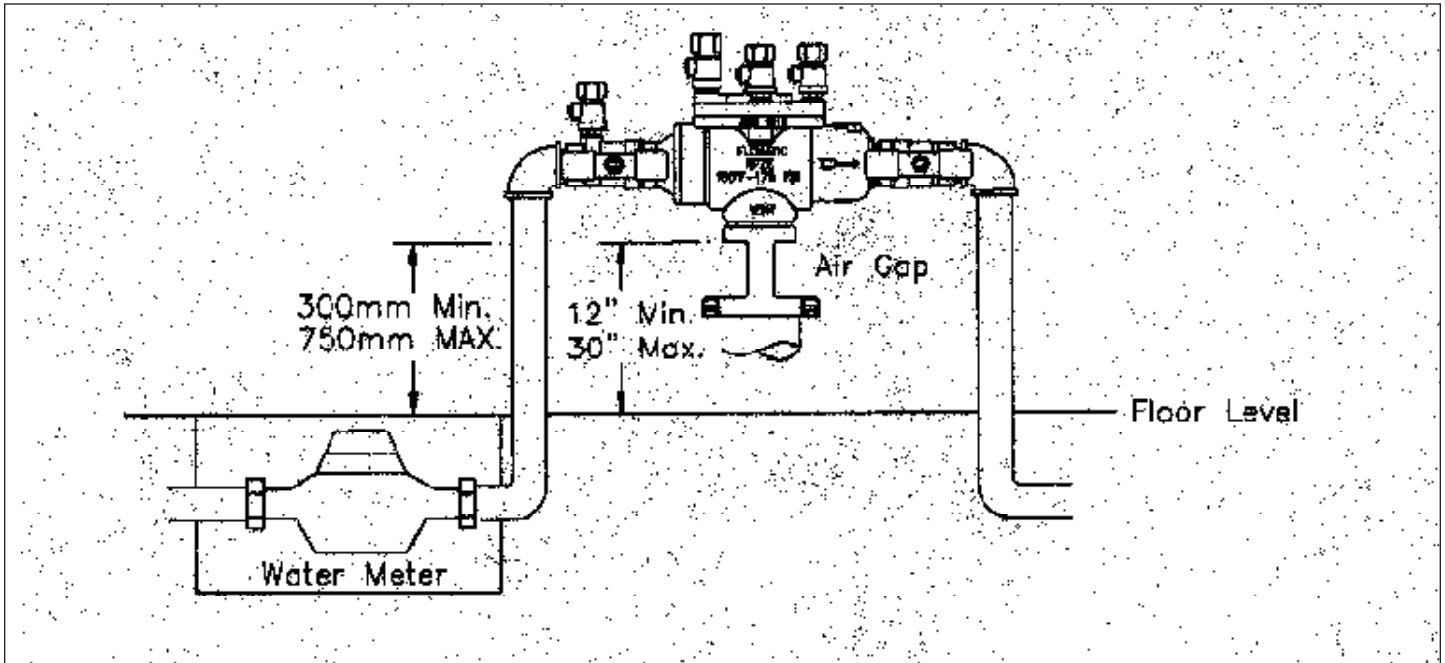

Features

- Bronze body, test cocks and ball valves
- Ultimate mechanical protection of potable water, against hazards of cross connection contamination
- Meets all specifications of AWWA, ASSE and all other major national approvals through the Cash Acme brand name.
- Non-interchangeable check valve assembly
- Replaceable check valve and removable 316 stainless steel relief valve seats
- Top-entry single access cover
- Vertical test cocks
- Low head loss
- Simple construction, fewer parts

Operation

The backflow preventer shall be a Reduced Pressure Principle and shall include a tightly closing resilient seated shut-off valve on each end of the body. The assembly shall be fitted with four (4) properly located resilient seated test cocks.

The assembly shall have two (2) independent and internally loaded check valves with a pressure differential relief valve located between the check valves.

The backflow preventer shall be suitable for **supply pressure up to 175 psi (1205kPa) and water temperatures from 33° to 180° F.**

CASH ACME® SPECIFICATIONS

The Reduced Pressure Principle backflow preventer shall protect against backflow by either backpressure or backsiphonage from a cross-connection between potable water systems and substances that are considered to have health hazards.

It shall consist of two (2) mechanically independent, spring loaded, center guided check valves. It shall also have a hydraulically dependent differential pressure relief valve, set in an integral cast bronze body, with a single access cover. The assembly shall have four (4) vertical test cocks and two shut-off valves which are quarter-turn, full-port, resilient seated and ball type.

The seat of each check valve and the relief valve shall be replaceable. The check valves shall be held into place by stainless steel clips and the check valve assemblies shall be non-interchangeable with silicone discs.

*Proper installation of the assembly is essential to the correct function of the assembly.
The following instructions are important characteristics of a proper installation.*

1. Before installing any of the Cash Acme® backflow assemblies, **flush the lines thoroughly** to remove all debris, chips and other foreign objects. Failure to do so may make any of these assemblies inoperable.
2. Allow sufficient clearance around the installed assembly to conduct testing (minimum 18" (450mm) around). The assembly should be installed in a horizontal position with a minimal clearance of 12" (300mm) between the relief valve discharge port and the flood level. The maximum height should be 30" (762mm) to allow for testing at a reasonable height.
3. Cash Acme RP assemblies are approved by national approval agencies and are to be installed in a horizontal position. Approval agencies do not recommend installation of a RP in a pit. Flooding of the pit can result in a cross connection contamination. If local codes permit installation of a RP in a pit, adequate drainage must be provided to prevent the pit from flooding.
4. Placement of the assembly should be planned where water discharge from the relief valve will not be objectionable or cause property damage.
5. Insure that the water supply pressure does not exceed the manufacturer's maximum water pressure or temperature. The unit should also be protected against thermal water expansion, extreme backpressure and/or water hammer.
6. The most common cause of field problems for RPs is dirt or debris in the system. At the time of installation dirt or debris will become trapped in the first check seating area, resulting in a continuous discharge from the relief valve in a static or backflow condition.

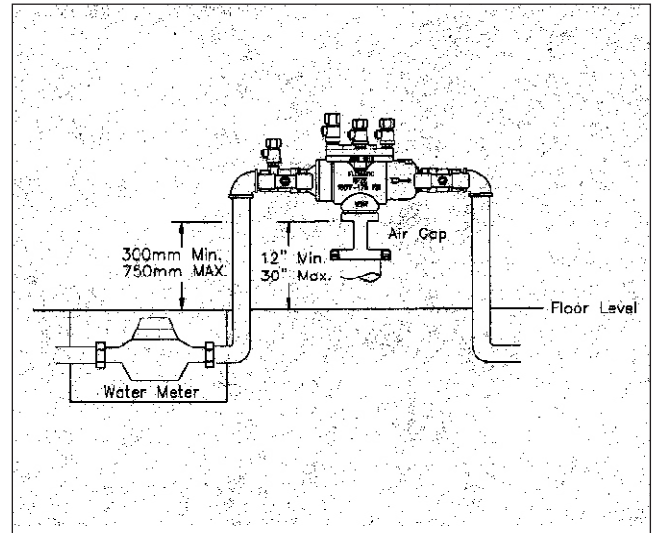

**THEREFORE THE SYSTEM SHOULD ALWAYS BE
FLUSHED BEFORE THE ASSEMBLY IS INSTALLED.**

7. To effectively flush the systems after the assembly has been installed, remove the internal components and open the inlet shut-off valve to flush all debris from the line and assembly. If debris in the water continues to cause problems, a strainer should be installed upstream of the assembly.

REDUCED PRESSURE BACKFLOW PREVENTERS

With Differential Pressure Gauge	
SYMPTOM NO. 1: Check Differential Across No. 1 Check Valve	
READING	PROBLEM
2 to 3 PSID 14 to 21 kPa	Leak in No. 1 or No. 2 check valve
6 to 8 PSID and steady 41 to 55 kPa	Malfunctioning pressure relief valve
2 to 7 PSID fluctuating 14 to 21 kPa	Inlet pressure fluctuating

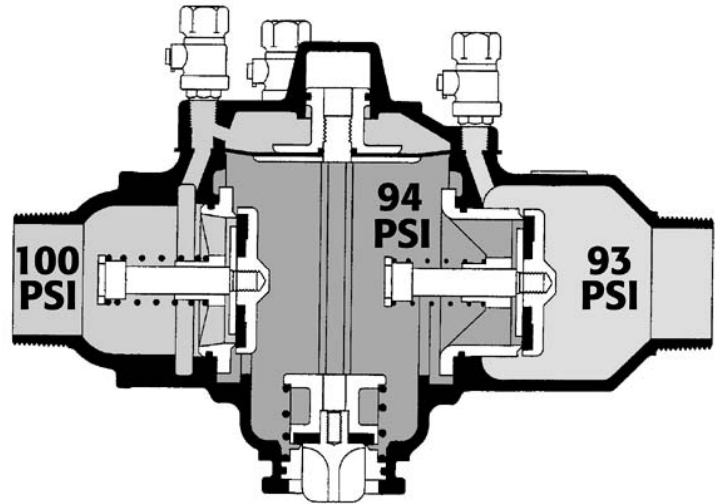

Static Pressure Condition

SYMPTOM NO. 1 and NO. 2: A) Close Ball Valve No. 2	
RESULT	PROBLEM
If discharge stops	Leak in No. 2 check valve
If discharge does not stop	Go to "B"

B) Open No. 4 testcock to produce a flow greater than differential relief valve discharge	
RESULT	PROBLEM
If discharge stops	Leak in No. 1 check valve
If discharge does not stop	Malfunctioning pressure relief valve

REDUCED PRESSURE BACKFLOW PREVENTERS

PROBLEM	CAUSE	SOLUTION
1. Valve releases water on and off from the relief valve.	1a. Inlet pressure fluctuations 1b. Outlet pressure fluctuations	1a. Install a soft seated, spring-loaded check valve on the inlet side of the assembly. (Cash Acme® Model 80E) 1b. Install a soft seated, spring-loaded check valve on the outlet side of the assembly as close as possible to the shut-off valve. (Cash Acme Model 80E)
2. Valve releases water constantly from the relief valve.	2a. Dirt or debris is on the first check. 2b. Damaged or dirty relief valve seat. 2c. Relief valve piston O-ring not free to move due to scale, dirt or build-up of mineral deposits. 2d. Excessive backpressure, freezing, or water hammer has distorted the second check. 2e. Valve improperly reassembled.	2a. Flush valve, if flushing does not work then clean or replace the first check. 2b. Clean or replace the relief valve seat. 2c. Clean, grease or replace the piston O-ring. 2d. Eliminate source of excessive backpressure or water hammer in the system downstream of the device. Use Cash Acme Model 80E to dampen out backpressure. In case of freezing; thaw, disassemble, and inspect internal components. Replace as necessary. 2e. Install check springs in their proper location.
3. Valve exhibits high-pressure Drop.	3a. Fouled strainer. 3b. Valve too small for flow.	3a. Clean strainer or replace. 3b. Install proper size device based on flow requirements.
4. No water flows downstream of valve.	4a. Valve installed backwards. 4b. Follow the Cash Acme test procedure. 4c. Leaky downstream gate valve.	4a. Install valve in accordance with flow direction arrow. 4b. Clean or replace gate valve with full port ball valves or resilient wedge shut-off valves.
5. Valve quickly and repeatedly fouls following servicing.	5. Debris in pipeline is too fine to be trapped by strainer.	5. Install a finer mesh strainer element in the strainer.

Cash Acme® backflow preventers can be serviced in the field with common household tools. All assemblies have a consistent design with all parts being located in the same locations and valves serviced in the same way.

1. First close inlet and outlet shut-off valves and bleed any pressure by opening the #4 test cock, then the #3 and #2.
2. Next use a wrench or socket to take the bolts out of top cover. After taking the cover off carefully inspect diaphragms, seals and seating surfaces for debris or damage (RP Fig.1, DC Fig.1a).

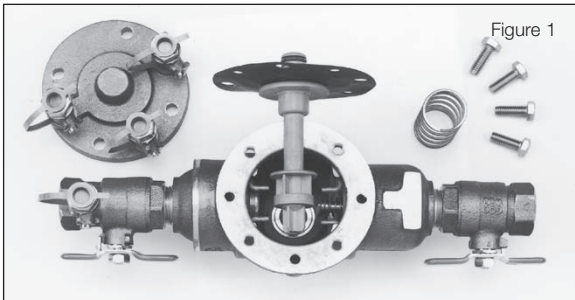

Figure 1

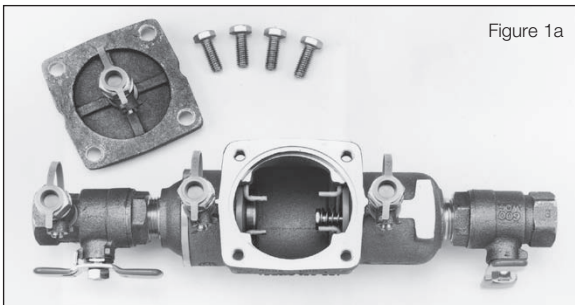

Figure 1a

3. After taking the cover off either check valve can be removed by simply using pliers to grasp the spring clip (RP Figure 2, DC Figure 2a).

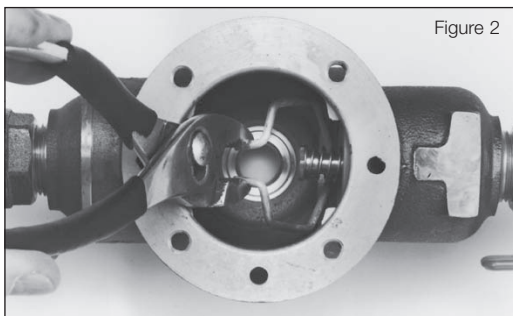

Figure 2

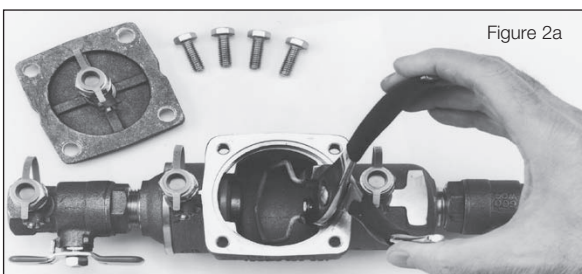

Figure 2a

4. Refer to parts list and figures for detailed parts. Do not use any petroleum based oils, grease, solvent or pipe dope on any of the parts. Use only lubricants that comply with FDA POTABLE WATER requirements for use in drinkable water systems or lubricants supplied by the manufacturer.
5. Next use a medium straight blade screwdriver to carefully pry the check valve out.
6. After check valve is out of the body, check for any build-up of calcium or other mineral deposits. If this condition exists, then carefully remove any build-up with a straight blade screwdriver. Also check the O-ring on the check valve for any cuts, if it is cut or has any deposits remove and replace or clean.
7. When check valve is out of the body grasp check valve disc holder and use a wrench or socket to unscrew the check valve stem from the disc holder (Figure 3).

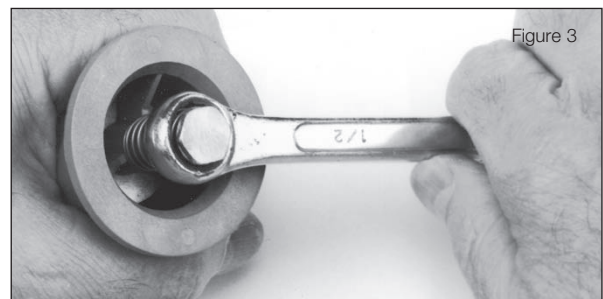

Figure 3

8. When check valve is disassembled, inspect the check valve seat for any cuts along the seat ring diameter. If seat is cut, it is a sign of high back pressure from thermal water expansion, water hammer or other causes of excessive water hammer. If seat is cut or damaged, it should be replaced, or turn used disc over if new seat disc is not available.

NECESSARY ITEMS:

Adjustable Wrench, Pliers, Flat head screwdriver, Socket wrench set and Loctite 242 (blue)

Visually inspect the rubber discs, springs and bolts for defects.

If check valve disc is damaged then call a service center or factory for a rubber kit. If the check valve seat ring or spring is damaged, call for a complete replacement check valve.

SUB-ASSEMBLIES: 1ST AND 2ND CHECK VALVES

1. Place check valve disc into check valve disc holder then place check valve disc retainer washer (with shiny side down and dull side up) over the check valve disc.
2. Place the 1st or 2nd check valve seat ring on top of the disc retainer and place O-ring around the slot in the seat ring. Then align these items with threaded hole in check valve disc holder.
3. Apply Loctite on the threads of the check valve disc holder.
4. Slide the spring down the shaft of the 1st or 2nd check valve seat ring.
(Use heavy spring for 1st check in RP units.)
5. Thread the check valve stem through the assembly and tighten the stem into threads on the check valve disc holder.

NOTE: RP and DC check valve assemblies are identical with the exception of the 1st check valve spring.



ITEM	DESCRIPTION
1	C.V. STEM
2	C.V. SPRING
3	2nd C.V. SEAT RING
4	C.V. O-RING
5	C.V. DISC REAINER
6	C.V DISC
7	C.V. DISC HOLDER

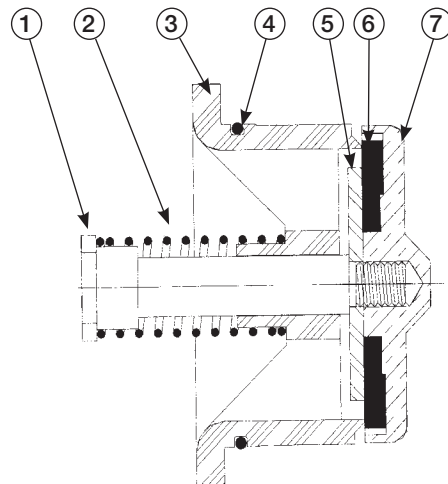

SERVICE PROCEDURES FOR RP 100/200 RELIEF VALVE Cash Acme® Valves

NECESSARY ITEMS:

Adjustable Wrench, Pliers, Flat head screwdriver, Socket wrench set, Loctite 242 (blue) and Relief Valve Assembly

1. After removing the cover of the backflow preventer then remove the relief valve assembly from body. Inspect the assembly for debris or damage.
2. Grasp the bottom disc retainer and use an Allen wrench to take the assembly apart. Turn the Allen wrench counter clockwise until the assembly is apart (Figure 1).

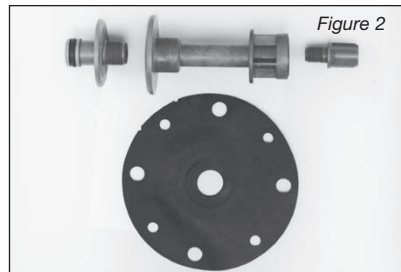
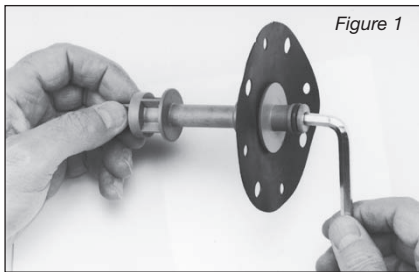

3. If the relief valve disc/rubber has dirt or debris on it, rinse in clean water. If the disc/rubber is cut or damaged beyond repair, contact service center or factory and request a rubber kit for the relief valve assembly.
4. Put relief valve diaphragm plate down the stem then place relief valve diaphragm on top of plate and screw piston onto stem.
5. Put the O-ring onto the relief valve piston.
6. Then place relief valve disc holder on the bottom of the shaft and put the relief valve disc/rubber into disc holder, then screw relief valve retainer into threads.

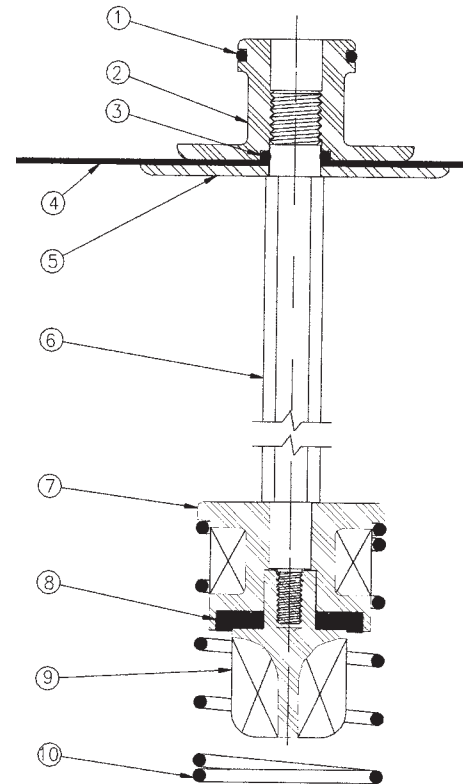

ITEM	DESCRIPTION
1	PISTON O-RING
2	R.V. PISTON
3	R.V. STEM O-RING
4	R.V. DIAPHRAGM
5	R.V. DIAPHRAGM PLATE
6	R.V. STEM
7	R.V. DISC HOLDER
8	R.V. DISC
9	R.V. DISC RETAINER
10	R.V. SPRING
RELIEF VALVE ASS'Y	

RP/DC BACKFLOW REASSEMBLY

Cash Acme® Valves

Visually inspect the valve body, springs and bolts for defects. Carefully remove any debris or foreign material with a flat head screwdriver.

DIRECTIONS FOR ASSEMBLY

1. Put lubricant on the 1st and 2nd check valve O-rings.
2. Put the 1st check valve into the body and secure with clamp.
3. Do the same for the 2nd check valve.
4. Lubricate relief valve O-ring with lubricant.
5. For the RP UNITS, lubricate the relief valve seat into body and put spring over the seat then align relief valve assembly with hole in seat and the holes in the diaphragm.
6. Place the RP/DC cover over the body and secure with bolts (on the RP units the 2 small slits on the diaphragm should face the inlet side).

How to Disassemble the RP-500

1. Close the Outlet Shut-off Valve (13), then close Inlet Shut-off Valve (12).
2. Release pressure from the assembly by opening Test Cocks 2, 3, 4.

CAUTION: The cover is spring-loaded and should be removed carefully to avoid personal injury

3. Use a Phillips-head screwdriver to remove the Relief Valve cover screws. while holding the cover (1) down.
4. Lift the cover (1) straight up.
5. Remove the Relief Valve assembly (3).
6. Remove the Relief Valve Spring (4).
7. Remove the Retainer (5).
8. Remove the Inlet and Outlet Check Valves (6) (7).

NOTE: Clean all the parts that have been removed. Then reassemble, or depending on their condition, discard and replace with new replacement parts. O-rings should be cleaned or replaced as necessary and light lubricated with NSF 61-approved lubrication.

How to Assemble the RP-500

1. Securely install the Inlet and Outlet Check Valves (6) (7).
2. Install the Retainer (5).
3. Place the Relief Valve Spring (4) in position
4. Install the Relief Valve Assembly (3).
5. Put on the cover (1), hold it down and tighten the screws.

CAUTION: Secure the screws with a recommended torque of 5 foot/pounds.

No. Part

1. Cover
2. Cover Screws
3. Relief Valve Assembly
4. Relief Valve Spring
5. Retainer
6. Inlet Check Valve Assembly
7. Outlet Check Valve Assembly
8. Body
9. Test Cocks (#1, #2, #3, #4)
10. Clamp Assembly
11. Adaptor Insert
12. Inlet Shut Off Valve
13. Outlet Shut Off Valve
14. Drainage Funnel

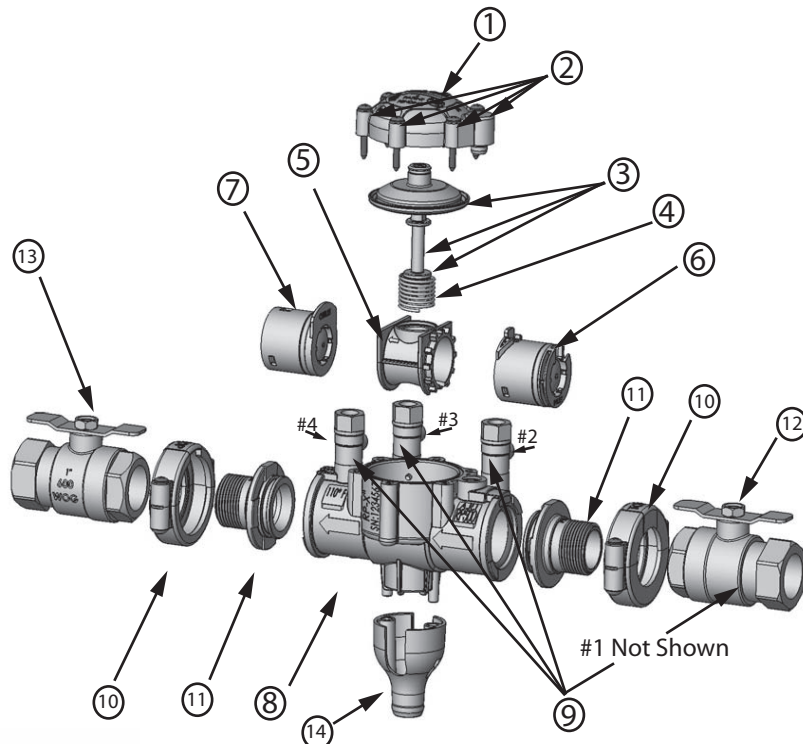



1. Removal of bonnet/poppet

- a. Close outlet ball valve then close inlet ball valve. Bleed residual pressure by opening No. 2 test cock.
- b. Remove canopy screws and canopy.
- c. Unscrew bonnet assembly from valve body by hand (if necessary, use appropriate size wrench on the outside diameter of bonnet).
- d. Remove poppet/seal and check for any cracks or debris. If it is dirty then clean with warm water.



Figure 1

2. Removal of check valve

- a. After removing the bonnet/poppet inspect the check valve.
- b. Use a 12 point 1-3/8" socket to unscrew check valve out from the body (see figure 2).
- c. Clean and inspect all components thoroughly prior to reassembly.
- d. Vent and check valve discs are reversible.
- e. Use flat head screwdriver to disassemble the check valve (see figure 3).

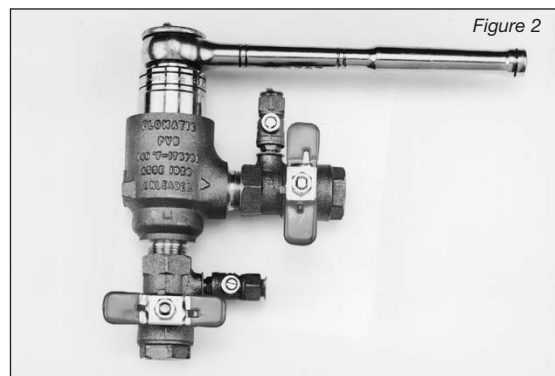

Figure 2

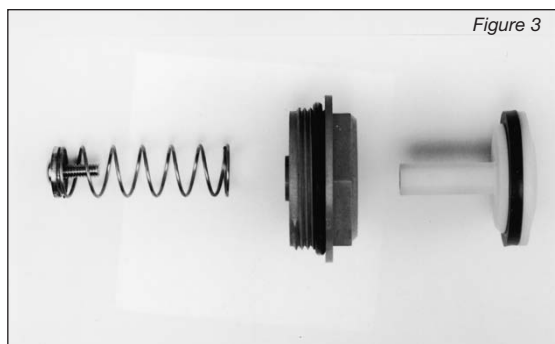

Figure 3

PVB Check Valve Assembly - For Models B9500 & B9501 Kit Model Number: 89598PO

Kit Parts	Part Description	Part Materials
9259200	Check Valve Disc Holder	GFC BASF#GC25A
9759300	Check Valve Disc	Silicone Rubber
9259400	Check Valve Seat Ring	Noryl™ GFN2 - 780s
9782900	Check Valve Seat O-Ring	Buna - N
9659600	Check Valve Spring	302 Stainless Steel
9359700	Check Valve Spring Retainer	Bronze B140-83
8474	#8-32 x 1/2 RHSTCS	18-8 Stainless Steel

PVB Air Vent Assembly - For Models B9500 & B9501 Kit Model Number: 89599PO

Kit Parts	Part Description	Part Materials
925860	Vent Canopy	ABS
9258700	Bonnet	Noryl™ GFN2 - 780s
9258700	Bonnet	Noryl™ GFN2 - 780s
9758800	Bonnet O-Ring	Buna - N
9658900	Vent Spring	302 Stainless Steel
9759000	Vent Disc	Silicone Rubber
9259100	Vent Disc Holder	Polyethylene
8473	Screws, 6-32x3/8	18-8 Stainless Steel

PVB Check Valve Assembly - For Models B9500 & B9501 Kit Model Number: B95RKO0

Kit Parts	Part Description	Part Materials
9758800	Bonnet O-Ring	Buna - N
9782900	Check Valve Seat O-Ring	Buna - N
9759000	Vent Disc	Silicone Rubber
9759300	Check Valve Disc	Silicone Rubber

MODEL RP100 & 200

Size	Relief Complete (4, 5, 6, 7, 8, 9, 20, 21, 22)	1st Check (10, 11, 12, 13, 14, 15, 16, 17)	2nd Check (10, 12, 14, 15, 16, 17, 18, 19)	Rubber Kit (5, 6, 8, 12, 15, 22)
1/2" & 3/4" RP200	89880P9	89878P9	89879P9	B93RK99
3/4" & 1"	89850P0	89848P0	89849P0	B92RK00
1-1/2" & 2"	89850P3	89848P3	89849P3	B92RK03
2-1/2" & 3"	89850P5	89848P5	89849P5	B92RK05
4"	89850P7	89848P7	89879P7	B92RK07
6"	89850P9	89848P9	89879P9	B92RK09
8"	89850P10	89848P10	89879P10	B92RK10

MODEL DC100

Size	1st Check	2nd Check	Rubber Kit
3/4" & 1"	89855P0	89849P0	B91RK00
1-1/2" & 2"	89855P3	89849P3	B91RK03
2-1/2" & 3"	89855P5	89849P5	B91RK05
4"	89855P7	89849P7	B91RK07
6"	89855P9	89849P9	B91RK09
8"	89855P10	89849P10	B91RK10

Better By Design
Air Gap Standard*
Silicone Discs
Top Entry Single Access Cover
Vertical Test Cocks

*Up to 2" RP 500

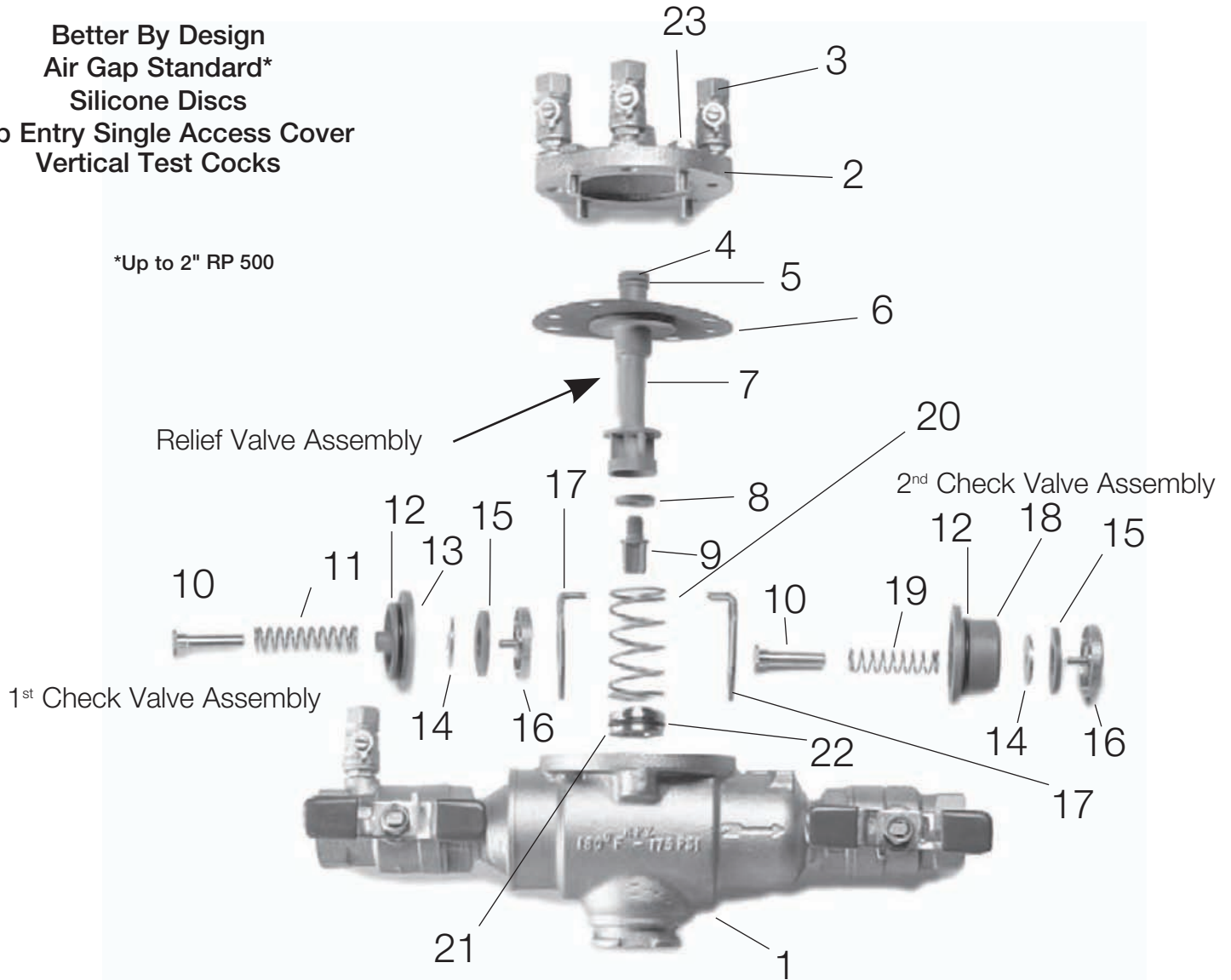

ITEM #	DESCRIPTION	QTY	ITEM	DESCRIPTION	QTY
1	BODY	1	13	1ST CV SEAT RING	1
2	COVER	1	14	1ST & 2ND CV w ASHER	2
3	TEST COCK	4	15	1ST & 2ND CV DISC	2
4	RELIEF VALVE PISTON	1	16	1ST & 2ND CV DISC HOLDER	2
5	RELIEF VALVE O-RING	1	17	1ST & 2ND CV SPRING CLIP	2
6	RV DIAPHRAGM / DIAPHRAGM PLATE	1	18	2ND CV SEAT RING	1
7	RV STEM / STEM O-RING	1	19	2ND CV SPRING	1
8	RV DISC / DISC HOLDER	1	20	RV SPRING	1
9	RELIEF VALVE DISC RETAINER	1	21	RV SEAT	1
10	1ST & 2ND CV STEM	2	22	RV SEAT O-RING	1
11	1ST CV SPRING	1	23	COVER BOLTS	4
12	1ST & 2ND CV O-RING	2			

MODEL DC500 1/2", 3/4" AND 1"

ITEM Description & Number	Catalog Number	
Cover Assembly - 1 (6 un.),2	0465-051-KIT	
Inlet Check Valve - 4,5,6,7,8,9	0465-0276-IN	
Outlet Check Valve - 4,5,6,7,9,10	0466-0276-OUT	
Clamp Assembly - 16,1 (2 un.),17	0466-99-KIT	
Adapter Assembly - 9,15	1/2"NPT	0466-4850NT-KIT
	3/4"NPT	0466-4834NT-KIT
	1"NPT	0466-4801NT-KIT
O-Ring Kit - 9 (4 un.),12,3	0465-5699-01-KIT	
Retainer - 11	0266-3101	

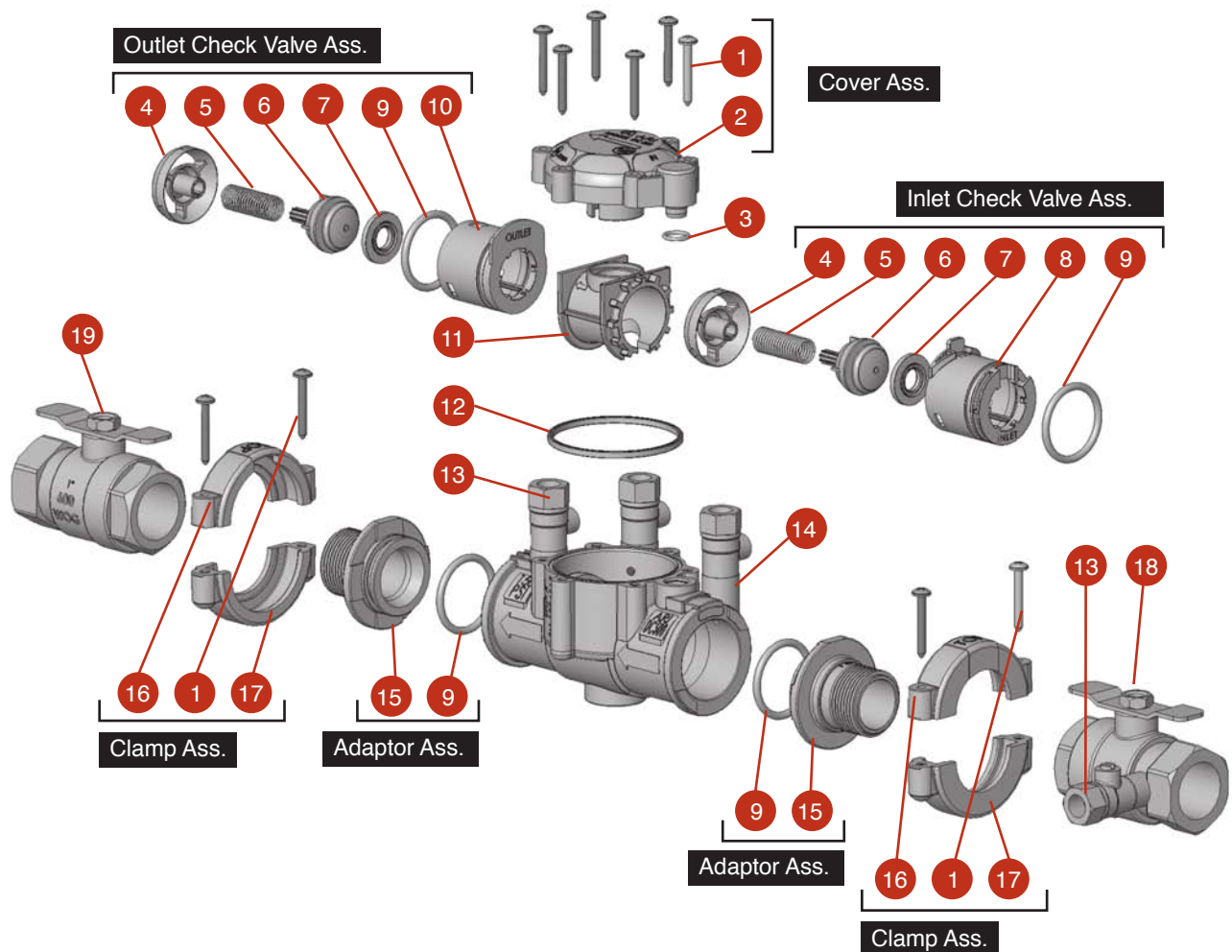

OVERBUILT IS AN UNDERSTATEMENT.®

MODEL DC500 1-1/2" AND 2"

ITEM Description & Number	Catalog Number	
Cover Assembly - 1 (8 un.), 2	0465-051-KIT	
Inlet Check Valve - 4, 5, 6, 7, 8, 9, 10, 11	0465-0276-IN	
Outlet Check Valve - 13, 5, 6, 7, 8, 9, 11, 12	0466-0276-OUT	
Clamp Assembly - 19, 1 (2 un.), 20	0466-99-KIT	
Adapter Assembly - 18, 11	1/2" NPT	0466-4850NT-KIT
	3/4" NPT	0466-4834NT-KIT
	1" NPT	0466-4801NT-KIT
O-Ring Kit - 11 (4 un.), 15, 3	0465-5699-01-KIT	
Retainer - 14	0266-3101	

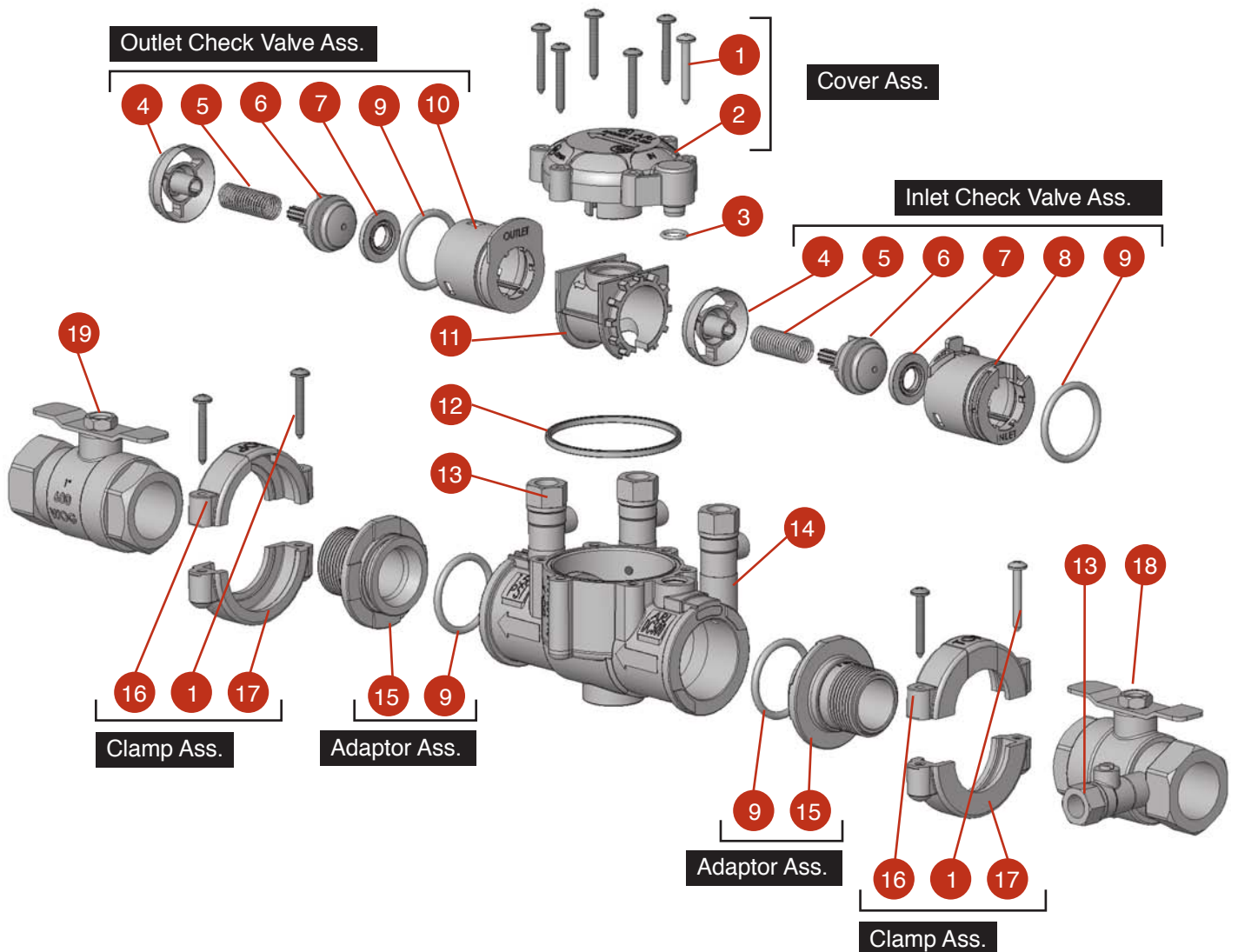

MODEL RP500 1/2", 3/4" AND 1"

ITEM Description & Number	Catalog Number
Cover Assembly -31 (6 un.), 7	0466-0501-KIT
Relief Valve Assembly -23, 24 (2 un.), 21, 19,18, 22, 20	0466-9601
Inlet Check Valve Assembly -14, 16, 11, 12, 15, 10	0466-0276-IN
Outlet Check Valve Assembly -14, 13, 11, 12, 10, 9	0466-0276-OUT
Clamp Assembly -27, 28, 31 (2 un.)	0466-99-KIT
Adapter Assembly - 8, 10	1/2" NPT 0466-4850NT-KIT 3/4" NPT 0466-4834NT-KIT 1" NPT 0466-4801NT-KIT
O-Ring Kit - 24 (2 un.), 10 (4 un.), 3	0466-5699-01-KIT
Relief Spring Valve - 17	0266-7696
Drainage Funnel - 25	0266-5101

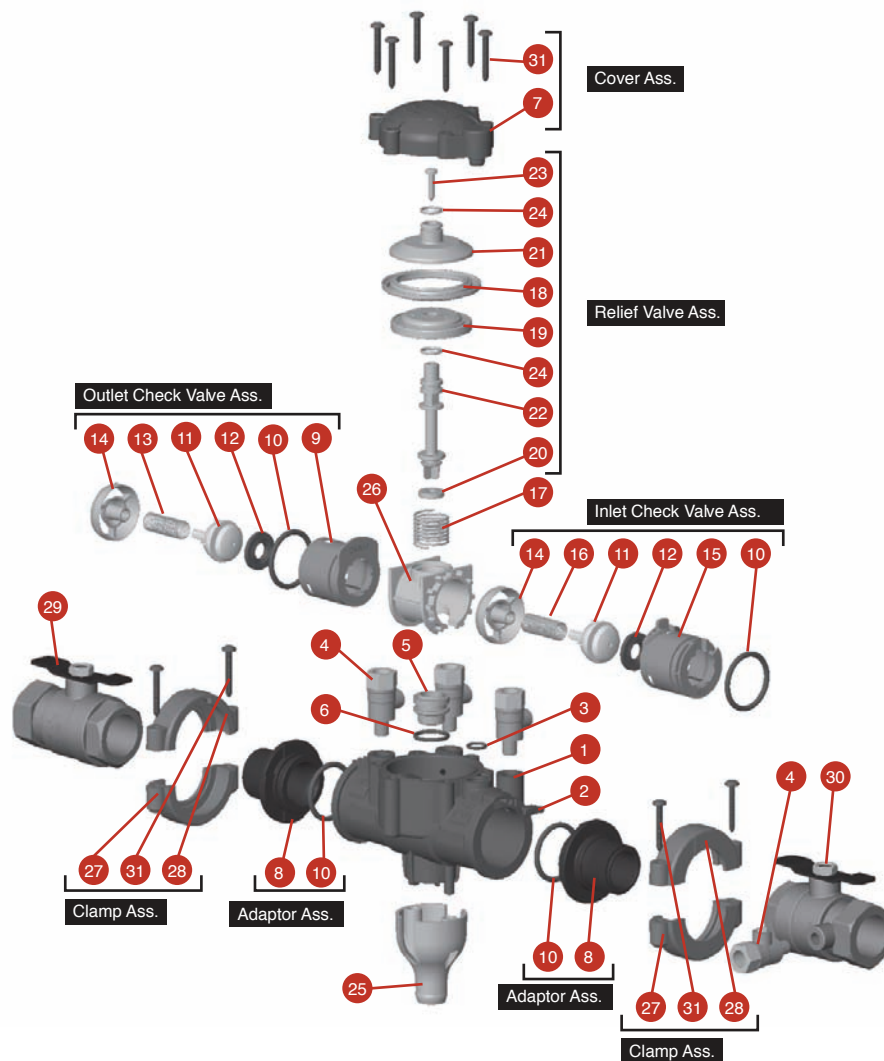

MODEL RP500 1-1/2" AND 2"

ITEM Description & Number	Catalog Number
Cover Assembly - 32 (8 un.), 6	0466-0502-KIT
Relief Valve Assembly - 23(2 un.), 24, 21, 26, 22, 20, 19	0466-9602
Inlet Check Valve Assembly - 18, 16, 11, 12, 8, 17, 15, 10	0465-0276-IN
Outlet Check Valve Assembly - 14, 13, 11, 12, 8, 17, 10, 9	0466-0276-OUT
Clamp Assembly - 28, 29, 32 (2 un.)	0466-9902-KIT
Adapter Assembly - 7, 10	1-1/2" NPT 0466-48112NT-KIT 1" NPT 0466-4802NT-KIT
O-Ring Kit - 10(4 un.), 24, 2	0466-5699-02-KIT
Relief Spring Valve - 25	0266-769602S2
Drainage Funnel - 33	0266-5102AN

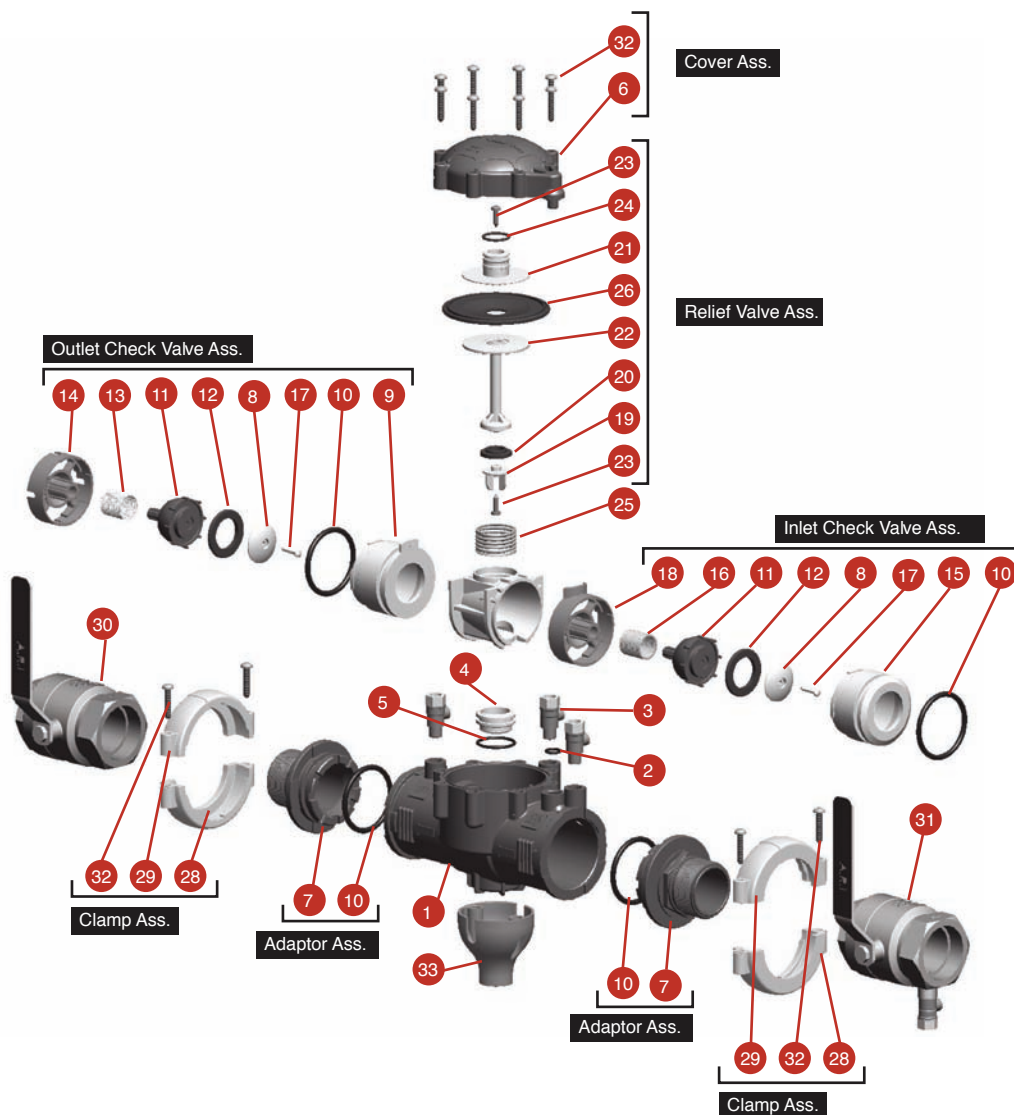

APPLICATION

Type of Device	Model	Back-Siphonage	Back-Pressure	Continuous Pressure	Low Hazard	High Hazard
Double Check Valve	DC	●	●	●	●	
Reduced Pressure Principle	RP	●	●	●	●	●
Pressure Type Vacuum Breaker	PVB	●		●	●	●

DEFINITIONS: Back-Siphonage: A form of backflow due to a reduction in system pressure resulting in a negative or sub-atmospheric pressure at a site in the water system.

Back-Pressure: Any increase of pressure in the downstream piping system above the supply pressure which would cause or tend to cause a reversal of the normal direction of flow.

Continuous Pressure: Extended or prolonged pressure.

Low Hazard: An actual or potential threat to the physical properties of the water system or the potability of consumer's water system, but which would not constitute a health or system hazard.

High Hazard: An actual or potential threat of contamination of a physical or toxic nature to the consumer's water system that would be a danger to health.

Return Goods Policy

Restocking charges and items returned for credit:

- New Standard Catalog Items - 20% restocking charged if returned for credit only. For items ordered in error, the charge will be reduced to 10% if replacement items are purchased.
- Special Order Items (products with special modifications) - 25% minimum to 50% maximum restocking charge, depending on modifications (consult factory).

All restocking charges are based on F.O.B. Cullman, Alabama and products being new (never having been installed in a line). We do not accept any valves which have been used. Prior to return of product, an R.G.A. number must be assigned by a customer service representative. This number should be references on the outside of the carton and on all related paperwork. Items should be returned prepaid to 2400 7th Avenue SW, Cullman, Alabama, 35055, marked "Attn: Returns Department." Any information or correspondence may be sent with the product or mailed separately.

Limited Warranty

Reliance Worldwide warrants each product against defects in material and workmanship for a period of three years from the date of the manufacturer. In the event of any defect within the warranty period Reliance Worldwide will at its option replace or recondition the product without charge providing the product is returned to Cullman, Alabama. This shall constitute the exclusive remedy for any alleged defect.

Reliance Worldwide shall not be responsible for any incidental, indirect, contingent or consequential damages, including, without limitation, damages or other costs resulting from labor charges, delays, loss of use, revenue or profit, vandalism, negligence, fouling caused by foreign material, damage from peculiar water conditions, chemicals or other circumstances over which Reliance Worldwide has no control; Reliance Worldwide makes no other warranties, express or implied, except as provided in this limited warranty. This warranty becomes voided by any misapplication, misuse, abuse or improper installation of the product. This warranty gives you specific legal rights and you may also have other rights which may vary from state to state. Applicable in the USA only.

Reliance Worldwide Statement of Policy

We reserve the right to make changes or improvements in our products without obligation to incorporate such changes or improvements in stock already manufactured. We will not replace or exchange new or improved products for older styles on customers' shelves. We also reserve the right to make substitutions in material or construction where necessary because of government regulations or availability of material.

We reserve the right to change the design of our products or their prices without notice. We also reserve the right to withdraw or drop a product from our line without notice.

For over seventy years, Reliance Worldwide has demonstrated its integrity, responsibility and technical skill, as evidenced by the continued patronage of its many customers and friends. It is our sincere desire to maintain full cooperation with customers and upon any questions arising in our transactions, we solicit your correspondence.

**Reliance Worldwide USA**

2727 Paces Ferry Road SE, Building Two, Suite 1800
Atlanta, GA 30339

1-877-700-4242 • Fax: 1-877-700-4280

In Canada:

1-888-820-0120 • FAX: 1-888-820-0121 • cashacme.ca

Product details at sharkbite.com or cashacme.com

Manufacturers and Distributors of  