



Water Hammer Arrestors

The Cash Acme Water Hammer Arrestors are engineered devices that provide a maintenance-free continuous protection system against detrimental destructive forces generated by the immediate cessation of water flowing in the water distribution system.

Cash Acme Water Hammer Arrestors provide a permanently sealed cushion of gas isolated from the waterway providing continuous protection and prolonging the service life of valves, piping, fittings, trim equipment, appliances, appurtenances, and other devices which are part of the distribution system. The Cash Acme Water Hammer Arrestors include a separate compressible gas chamber to absorb and dissipate the energy to a safe level.

- One moving part in the product: *Maintenance-Free*
- Designed for vertical and horizontal installations: *Flexible installation options in new or existing plumbing systems.*
- Robust and simple construction: *Superior reliability and increased service life of other devices in distribution system.*
- Suitable for all potable water applications: *Designed to operate domestic and commercial water distribution systems. (Available with NPT Thread, Sweat or Hose Connection.)*



TYPICAL INSTALLATION

The Cash Acme Water Hammer Arrestor reduces fluid hammer caused by the sudden halt of water flowing in the water distribution system.

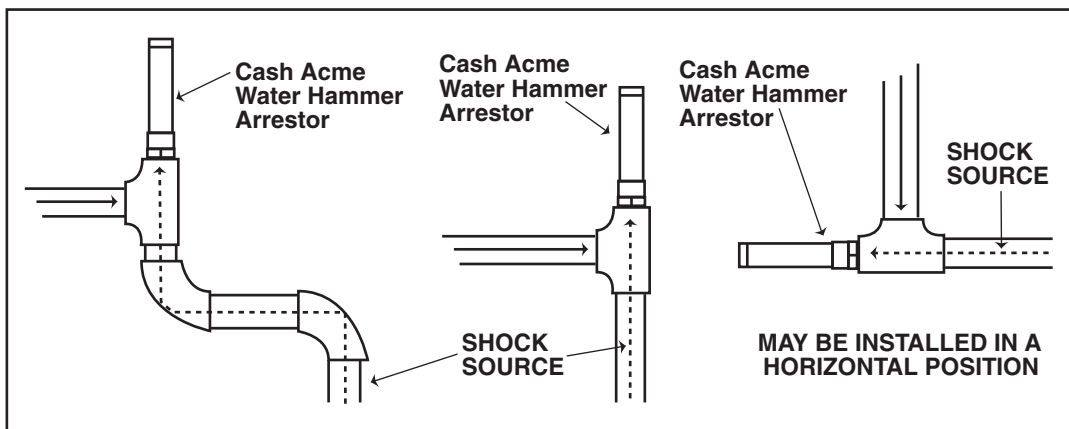



Water Hammer Arrestors

CONNECTIONS

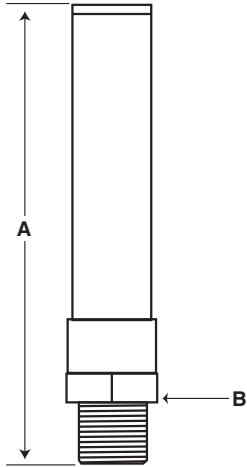

Water Hammer Arrestor Dimensions

Model	A (in.)	B (in.)
CC-500	5	1/2 NPT
CWA-500	7	1/2 CTS
CC-750	6	3/4 NPT
CWA-750	9-1/4	3/4 CTS
CC-1000	6-3/4	1 NPT
CWA-1000	9	1 CTS
CC-1250	8-3/8	1-1/4 NPT
CWA-1250	8-3/8	1-1/4 CTS
CC-1500	10-1/4	1-1/2 NPT
CWA-1500	10-1/4	1-1/2 CTS
CC-2000	10-7/8	2 NPT
CWA-2000	10-7/8	2 CTS

CTS - copper tubing size

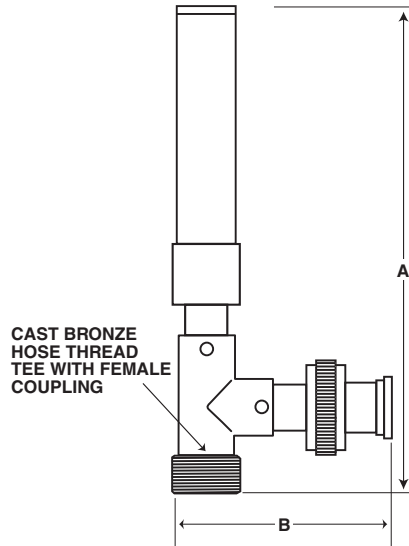

Laundry Mini Dimensions

Model	A (in.)	B (in.)
CM-500	6-1/4	1/2 CTS
CM-500SWA	7	1/2 NPT
CM-500TH	4-7/8	3

CTS - copper tubing size

SIZES

Domestic:

- Sweat 1/2"
- Threaded 1/2"
- CPVC 1/2"
- PEX 1/2"
- Compression 1/2"

Commercial:

- Sweat 1/2", 3/4", 1", 1-1/4", 1-1/2"
- Threaded . . . 1/2", 3/4", 1", 1-1/4", 1-1/2", 2"

CERTIFICATIONS

The Cash Acme Water Hammer Arrestor is design certified to ASSE 1010 Product Standard and is listed by ASSE.