

VR-801 Vacuum Relief Valve

DESCRIPTION

The Cash Acme VR-801 Vacuum Relief Valve is designed to protect hot water supply systems and pressure vessels against negative pressure. It is especially well suited for many domestic and commercial systems.

It works by preventing internal vacuum conditions that could result in burned out heaters and/or collapsed storage tanks – especially copper.

Installed on the cold water supply line, the **Cash Acme VR-801** closes tightly under pressure and opens at a 1" mercury vacuum. Atmosphere admitted to the system breaks the vacuum, preventing collapse of the storage tank. It is recommended that the **VR-801** be installed in an upright position.

The **Cash Acme VR-801** is available in sizes 1/2" and 3/4" with male inlets. The **VR-801** also features a low profile design with a slotted vent hole. This valve features an all brass body and body cap, a heat-resistant silicone seat disc, an integral body seat and brass internal working parts. Also comes with an optional circular dust cover that is approx. 1.75" in diameter.

FEATURES AND BENEFITS

Prevents internal vacuum conditions:

Guards against siphonage, burnt-out heaters and collapsing of storage tanks and negative pressure.

Opens quickly in emergency situations:

Opens on a one inch mercury vacuum.

Listed by CSA:

Inspector friendly, peace of mind!

Every valve is tested for performance prior to shipping:

Specify and install with confidence!

SPECIFICATION

A vacuum relief valve shall be installed to protect the pressure vessel. The valve shall be CSA certified per ANSI Z21.22. The valve shall be constructed of brass with an integral body seat disc. The valve shall open on a one inch mercury vacuum. The valve shall be a **Cash Acme VR-801 Vacuum Relief Valve**.

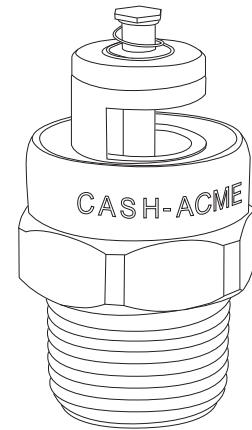

VR-801

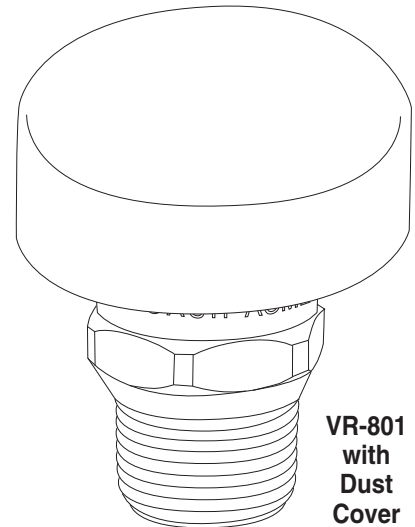

VR-801
with
Dust
Cover

VR-801 Vacuum Relief Valve

TYPICAL INSTALLATION

It is recommended that the **VR-801** be installed in an upright position. For further installation information, please contact the factory.

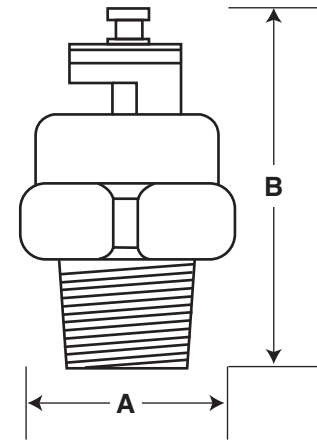
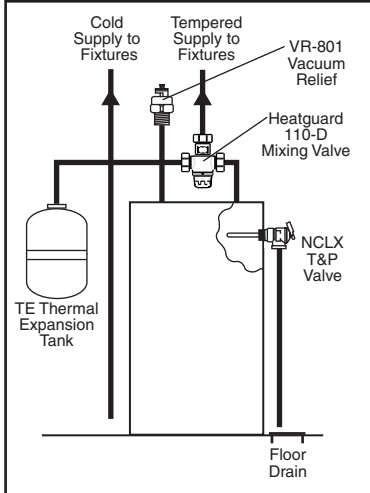

VR-801

Dimensions	A	B
1/2"	1 3/8"	2 5/16"
3/4"	1 3/8"	2 5/16"

SPECIFICATION DATA

Performance:

- Relief pressure (open) 1" Hg vacuum
- Capacity 13 SCFM (@ 2" Hg)
- Maximum temperature 210°F
- Maximum inlet pressure 200 psi
- Service Water

Materials:

- Body Brass
- Body Cap Brass
- Internal Parts Brass
- Seat Disc Silicone
- Spring Stainless steel
- Dust Cover Polypropylene

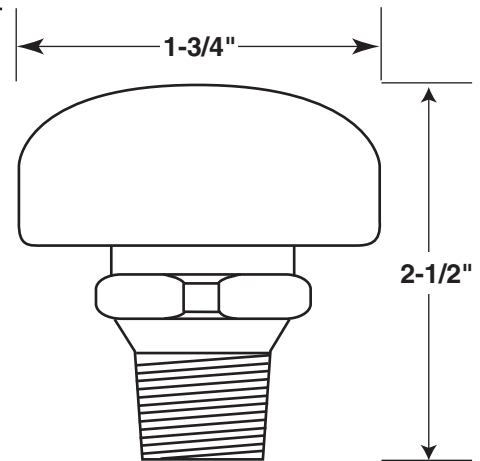

VR-801 with Dust Cover

CONNECTIONS

Threaded (NPT) 1/2" and 3/4"

CERTIFICATIONS

The **Cash Acme VR-801 Relief Valve** is certified to ANSI Z21.22 and listed by CSA.