

# Heatguard® 110-DLF Series

## DESCRIPTION

The Heatguard® 110-D LF is a Temperature Actuated Mixing Valve that mixes hot water with cold to deliver tempered water at a controlled temperature to 120°F maximum. The Heatguard® 110-D LF is designed to assist in the prevention of scalding.

The Heatguard® 110-D LF is intended for installation at the water heater to distribute controlled temperature water through a domestic hot water system. The valve delivers water at a maximum of 120°F, allowing the heater to be set at 140°F or higher, thus providing a greater effective volume of hot water and reducing the chances of Legionella bacteria growth in the water.

The Heatguard® 110-D LF is a high quality mixing valve incorporating the latest in Thermostatic Technology. It features a robust design based on the expertise gained from years of experience in the design and manufacture of safety valves. Every valve is tested for performance on an automated testing station during the assembly process. The valve is third party listed for both distribution and point-of-use applications.

The Heatguard® 110-D LF incorporates a fast acting, high quality thermostatic element that senses the outlet water temperature and reacts to maintain a stable delivery temperature even under changing flows or variations in supply temperatures. The valve also greatly reduces the outlet flow in the event of a cold water supply failure.

The Heatguard® 110-D LF features a lockable cover over a spindle mechanism.

The Heatguard® 110-D LF is available as a base valve with union connections to suit the range of Heatguard Fittings Kits in 1/2", 3/4" and 1" sizes, including sweat, CPVC, PEX, threaded, 4 in 1 service fittings and SharkBite®.

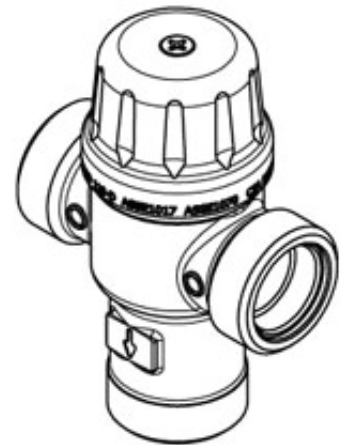

**HEATGUARD®**  
THERMOSTATIC MIXING VALVES

## FEATURES AND BENEFITS

Certified for distribution and point-of-use applications.  
*Safer hot water from all outlets.*

Allows the heater to be set at 140°F or higher:  
*Greater effective hot water volume yields less chance of Legionella within the cylinder.*

Every valve is tested for performance prior to shipping:  
*Specify and install with confidence!*

Robust, low complexity construction:  
*Superior reliability, improved user safety.*

Unique, purpose designed adjuster tool:  
*Minimizes unauthorized tampering with valve setting.*

Listed by IAPMO and ASSE:  
*Inspector friendly, peace of mind!*

## SPECIFICATION

A Temperature Actuated Mixing Valve shall be installed at single fixture or at the water heater to distribute tempered water throughout the domestic hot water system at a maximum of 120 °F. The valve shall be third party listed. The temperature actuated mixing valve shall control the delivered water temperature via a regulating piston made from engineering polymer. The adjusting mechanism shall be protected by a lockable cover. The valve shall be a Cash Acme Heatguard® 110-D LF.

# Heatguard® 110-DLF Series

## TYPICAL INSTALLATION

To control water temperature at the source of heat (hot water tank) to provide a safe distribution of temperature.

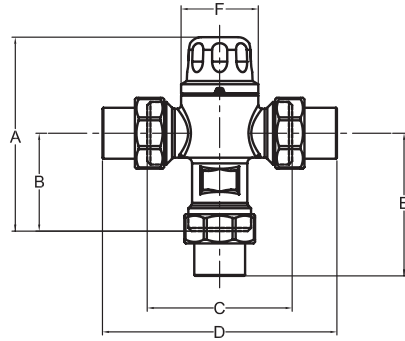
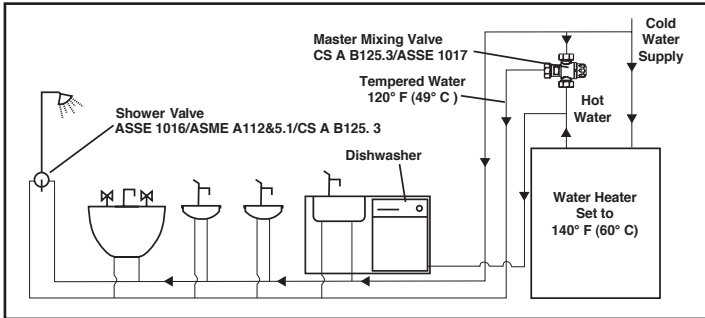

Dimensions	A	B	C	D	E	F
Base Valve	4.1 (103)	2.1 (52)	3.0 (76)	*	*	1.6 (41)
1/2" Sweat	4.1 (103)	2.1 (52)	3.0 (76)	4.4 (112)	2.6 (66)	1.6 (41)
3/4" Sweat	4.1 (103)	2.1 (52)	3.0 (76)	4.9 (124)	3.0 (76)	1.6 (41)
1" Sweat	4.1 (103)	2.1 (52)	3.0 (76)	7.2 (184)	4.2 (106)	1.6 (41)

## SPECIFICATION DATA

### Performance:

- Outlet temperature range . . . . . 90 - 130 °F (32 - 54 °C)
- Temp. hot supply . . . . . 195 °F (90 °C) max.
- Temp. cold supply . . . . . 39 - 80 °F (5 - 27 °C)
- Temp. stability . . . . . +/- 5 °F (3 °C)
- Working pressure . . . . . Max. 145 psi (1,000 kPa)
- Flow rate, minimum . . . . . 1.0 gpm
- Flow rate, maximum . . . . . 20 gpm

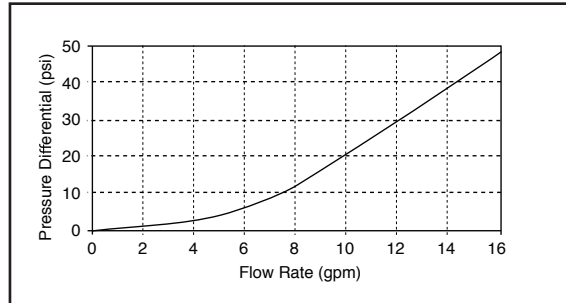

### Materials:

- Body . . . . . Lead Free Bronze, nickel plated
- Seals . . . . . Viton
- Springs . . . . . Stainless steel
- Internal Cap . . . . . Lead Free Brass
- Piston . . . . . Polysulphone Noryl GFN
- Guide tube . . . . . Engineered polymer

## CONNECTIONS (sold separately)

- Sweat . . . . . 1/2", 3/4" and 1"\*
- Sweat w/ check . . . . . 1/2" and 3/4"
- Barb . . . . . 1/2", 3/4" and 1"
- Barb w/ check . . . . . 1/2", 3/4" and 1"
- Threaded (NPT) . . . . . 1/2" and 3/4"
- Threaded (NPT) w/ check . . . . . 1/2" and 3/4"
- CPVC . . . . . 1/2" and 3/4"\*
- CPVC w/ check . . . . . 1/2" and 3/4"\*
- SharkBite® Connection . . . . . 1/2" and 3/4"\*
- SharkBite® Connection w/ check . . . . . 1/2" and 3/4"\*

\*Available in Lead Free

## CERTIFICATIONS

The Cash Acme Heatguard® 110-D LF is certified to ASSE 1017, ASSE 1070 and CSA B125.3. The Cash Acme Heatguard® 110-D LF is listed by ASSE and IAPMO for use in accordance to all U.S. and Canadian plumbing codes.