

Heatguard® 160 4 in 1 Series

DESCRIPTION

The Heatguard® 160 4 in 1 is based on the superior performance Heatguard® 160 Thermostatic Mixing Valve complete with 4 in 1 Service Fittings.

The Heatguard® 160 4 in 1 is a superior performance Thermostatic Mixing Valve that mixes hot water with cold to deliver tempered water at a constant temperature. The Heatguard® 160 4 in 1 is intended to supply controlled temperature hot water to any outlet requiring a higher level of protection, such as a tub or basin in a nursing home or lavatory faucets in a public place.

The Heatguard® 160 4 in 1 has all the same features as the standard Heatguard® 160 with the added feature of multi-function inlet fittings. The 4 in 1 Service Fittings provide:

1. Integral ball valve isolator
2. Large area cylindrical strainer
3. Gauge/flushing port to measure pressure or as flushing point
4. Check valves to prevent cross-connection of hot to cold

The Heatguard® 160 4 in 1 is a high specification product incorporating the latest in Thermostatic Technology. It features a robust design based on the expertise gained from years of experience in the design and manufacture of safety valves. Every valve is tested for performance on an automated testing station during the assembly process. The valve is third party listed for individual point-of-use applications.

The Heatguard® 160 4 in 1 features a rapid response thermostatic element for superior control. The thermostatic element senses the outlet water temperature and reacts to maintain a constant delivery temperature even under changing flows or variations in supply temperatures or pressures. The valve also reduces the outlet flow to a trickle in the event of a cold water supply failure.

The Heatguard® 160 4 in 1 features a snap-on cover over a spindle mechanism that requires a special tool to adjust the temperature. The special tool is provided with each valve.

The Heatguard® 160 4 in 1 is complete with Service Fittings on each inlet. The Service Fittings have a 1/2" female inlet thread and connect to the base valve via union connections. The outlet has a 1/2" female fitting via a union connection to the valve body.

FEATURES AND BENEFITS

Complete with 4 in 1 Service Fittings:

Easier and quicker to install, service and test.

Every valve is tested for performance prior to shipping:

Specify and install with confidence!

Accurate temperature control, even under varying supply conditions:

Increased user comfort and convenience.

Total flow shut-off if cold supply fails:

Greater end user safety.

Unique, purpose designed adjuster tool:

Minimizes unauthorized tampering with valve setting.

Listed by ASSE and IAPMO:

Inspector friendly, peace of mind!

SPECIFICATION

A Thermostatic Mixing Valve shall be installed to deliver controlled temperature hot water to each fixture. The valve shall be third party listed. The thermostatic mixing valve shall control the delivered water temperature via a regulating piston made from engineering polymer. The valve shall have integral poppet style check valves on both inlets with a positive seal of the poppet onto an elastomer seat to prevent cross connection from hot to cold. The valve shall be complete with integral ball valve isolators, strainers, check valves and gauge/flushing ports on each inlet. A special tool shall be required to adjust the outlet temperature and the adjusting mechanism shall be hidden by a snap-on cover. The valve shall be a Cash Acme Heatguard® 160 4 in 1.

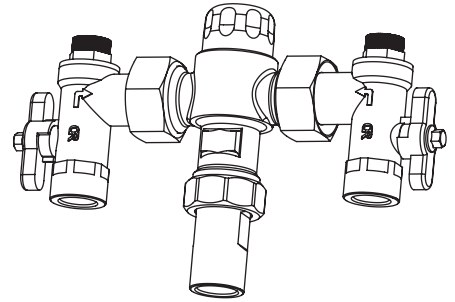

HEATGUARD®
THERMOSTATIC MIXING VALVES

Heatguard® 160 4 in 1 Series

TYPICAL INSTALLATION

The Heatguard® 160 4 in 1 is a high performance Thermostatic Mixing Valve (TMV) designed to deliver mixed water to a single outlet. It may also be used to supply multiple outlets. It makes allowances for any change in supply conditions to ensure that the outlet water temperature remains constant.

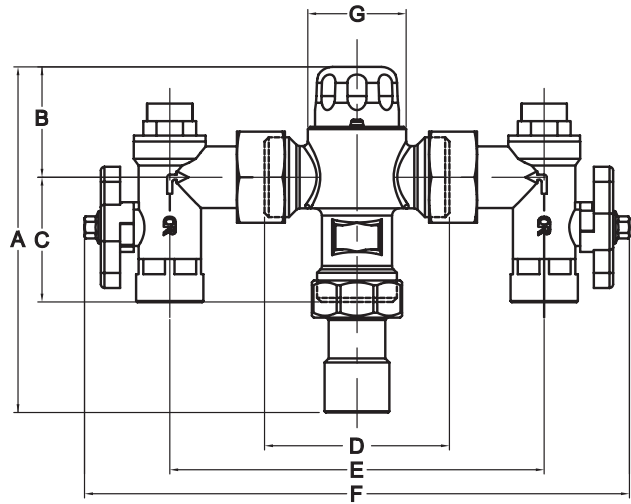
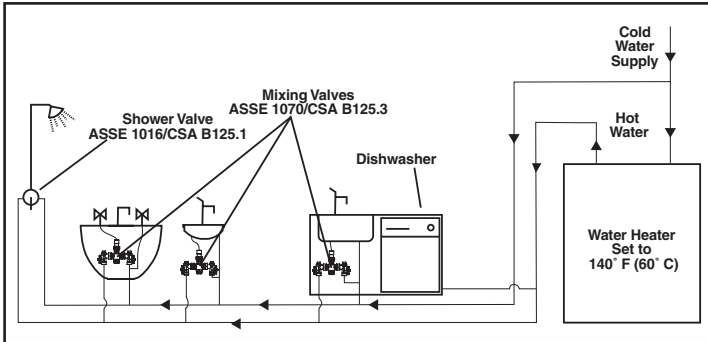

Dimensions	A	B	C	D	E	F	G
Base Valve	5.7 (144)	1.8 (46)	2.0 (52)	3.0 (76)	6.1 (156)	8.9 (227)	1.6 (41)

Inches (mm)

SPECIFICATION DATA

Performance:

- Outlet temperature range 95 - 115°F (35 - 46°C)
- Temperature hot supply 195°F (90°C) max.
- Temperature cold supply 40 - 80°F (4 - 27°C)
- Temperature stability +/- 3°F (1.7°C)
- Working pressure, maximum . . 145 psi (1,000 kPa)
- Flow rate, minimum 1 gpm (4 L/min)
- Flow rate, maximum 11 gpm (42 L/min)

Materials:

- Body Bronze, nickel plated
- Seals Nitrile elastomer
- Springs Stainless steel
- Fitting Brass
- Internal Brass
- Piston Engineered polymer

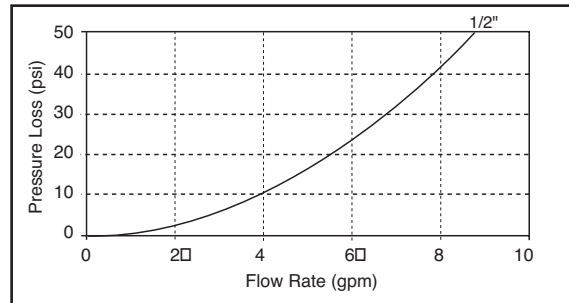

CONNECTIONS

1/2" Female threaded inlets and outlets

CERTIFICATIONS

The Cash Acme Heatguard® 160 is certified to ASSE 1069, ASSE 1070, & CSA B 125.3, and is listed by ASSE and IAPMO.