

Temperature Control For Hot Water

Reference Guide to the Canadian Plumbing Code Change

HEATGUARD[®]
THERMOSTATIC MIXING VALVES



OVERBUILT IS AN UNDERSTATEMENT.™

www.cashacme.ca

Heatguard® Reference Guide

TABLE OF CONTENTS

Introduction	pages 2-3
Frequently Asked Questions About Water Heater Safety	page 4
Canadian Plumbing Code	pages 5-6
Heatguard® Series General Information	pages 7-8
Heatguard® 110-D Series	page 9
Heatguard® 115-D Series	page 10
Heatguard® 145 Series	page 11
Heatguard® 160 4in1	page 12
Masterguard® 800 Series	page 13
Heatguard® Fittings and Accessories	page 14
Heatguard® Product Features	page 15
Troubleshooting Guide	page 15

THE PROBLEM

1. SCALDING

High water temperatures are dangerous! The higher the water temperature the shorter the time taken to scald. It is commonly accepted that water temperatures higher than 49°C (120°F) should not be available at outlets used for bathing purposes. At 49°C (120°F) it takes approximately 5 minutes to sustain a full thickness burn. An increase to only 55°C (131°F) dramatically reduces the time for a full thickness burn to less than 1 second for a child!

2. LEGIONELLA BACTERIA

This bacteria thrives in warm water environments (i.e.; 49°C [120°F] or less), and is thus a potential problem in hot water distribution systems. Water stored at 49°C (120°F) or less can provide ideal conditions for the growth of Legionella bacteria within the water heater. It is necessary to store water at 60°C (140°F) or higher to minimize the bacteria growth.

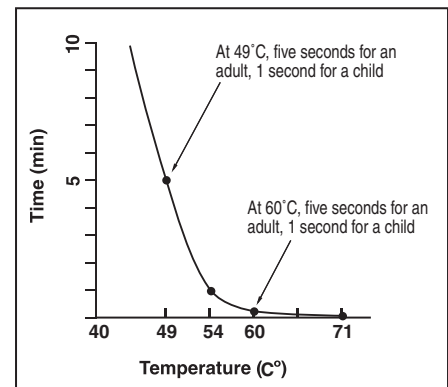

LEGIONELLA AND TEMPERATURE

- 20°C (68°F) and below - Legionella is dormant
- 35° - 46°C (95° - 114°F) - Ideal growth range for Legionella bacteria
- 55°C (131°F) - Destroyed in 5 - 6 hours
- 60°C (140°F) - Destroyed in 2 minutes (scalding risk)
- 70°C (158°F) and above - Disinfection range

So, how can the two apparently conflicting problems of scalding and Legionella be overcome?

Heatguard® Series



THE SOLUTION

The Cash Acme Heatguard® Thermostatic Mixing Valve!

The use of an ASSE 1017/CSA B-125 approved thermostatic mixing valve is the solution. The mixing valve will allow for the water to be stored at 60°C (140°F) to reduce the growth of legionella, and delivered to the fixture at 49°C (120°F) to reduce the risk of scalding.

Features and Benefits

- Delivers water at a maximum of 49°C (120°F) throughout the system:
 - Safer hot water from all outlets.
- Allows the heater to be set at 60°C (140°F) or higher:
 - Greater effective hot water volume yields less chance of Legionella within the cylinder.
- Every valve is tested through a range of tests prior to shipping:
 - Specify and install with confidence!
- Robust, low complexity construction:
 - Superior reliability, improved user safety.
- Unique, purpose-designed adjuster tool:
 - Minimizes unauthorized tampering with valve setting.
- Listed by ASSE (ASSE 1017) and IAPMO (cUPC to ASSE 1017 and CSA B-125):
 - Inspector friendly, peace of mind!

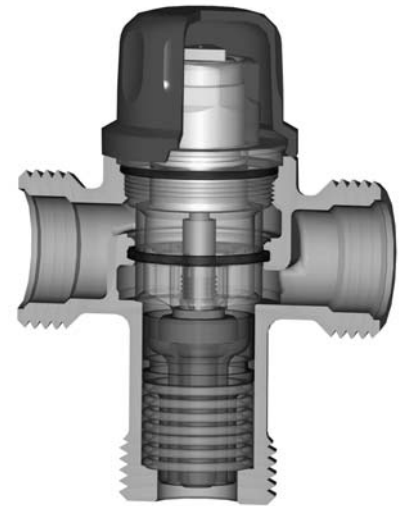

HEATGUARD®
THERMOSTATIC MIXING VALVES

NEW
CANADIAN PLUMBING
CODE RECOGNIZES USE OF
THERMOSTATIC MIXING VALVES
TO SOLVE THE DUAL PROBLEM OF
SCALDING AND LEGIONNAIRES;
SEE PAGES 5&6 FOR
DETAILS!

Gallons of Hot Water by Storage Temp*				
Storage Temp (°C/°F)	Cold Water Temp. (°C/°F)			
	7/45	13/55	18/65	24/75
49/120	30	30	30	30
60/140	38	39	41	43
71/160	46	48	52	57
82/180	54	58	63	70

*Effective heater capacity with higher storage temperature for 30 gal. tank.

THE PRODUCT

Heatguard®

Reliance Worldwide is the global market leader in the manufacture of under counter/ small distribution thermostatic mixing valves. Now a part of Reliance, Cash Acme offers the proven reliability of more than 2 million successful installations worldwide. Our experience over the last 50 years in the manufacture and distribution of safety valves for residential, commercial and industrial markets has led to the development of a complete range of valves to provide safe water temperature.

ADDITIONAL INFORMATION

See these links for additional information:

- http://www.pulsus.com/Infdis/15_01/leve_ed.htm - An editorial in the January/February 2004 edition of The Canadian Journal of Infectious Diseases
- <http://www.awt.org> - The homepage for the Association of Water Technologies report on Legionella
- <http://www.cashacme.ca/watertemp.html> - Information on hot water temperature, scalding, and Legionnaires' Disease

WHO IS AT RISK OF SUFFERING TAP WATER SCALDS?

Children have thinner and more sensitive skin than adults. A scald will damage a child's skin more deeply and quickly than an adult's skin. At 60°C (140°F), water will cause third degree burns on an adult in five seconds and on a child in one second (at 71°C [160°F], the time period drops to one second for an adult and half of a second for a child). Another group that is vulnerable to scalding is the elderly. Seniors have decreased sensitivity of the skin (in addition to having thinner and more fragile skin), so they are less aware of potentially scalding water. Also, the elderly are more susceptible to falling and slipping in the shower to avoid scalding water. The final group that is at risk is the mentally challenged and physically handicapped. Due to diminished capacity and mobility, they may have difficulty comprehending or escaping dangerous situations in which scalding water is a factor. Tap water generally causes more severe scalding because more of the body is exposed to the dangerous water.

CAN'T I JUST TURN MY WATER HEATER DOWN TO PREVENT SCALDING?

There are two main reasons that turning your water heater down to prevent scalding is an insufficient solution: (1) Water heaters set at lower temperatures reduce the capacity to deliver hot water, and, most importantly, (2) The risk of bacterial growth is an issue that is frequently connected with lower water temperatures, primarily when the water is stagnant. Legionella is a common bacteria-causing organism that can prove to be the biggest danger. This particular organism causes Legionnaires' disease, a potentially fatal form of pneumonia. Legionella thrives in luke-warm, stagnant water like that found in ponds and lakes, and the bacteria may thrive in a water heater that is turned down too low. The bacterium actually becomes airborne through the water particles and infects the lungs after it is inhaled. The Center For Disease Control in Atlanta estimates that there are 10,000-15,000 cases of Legionnaires' disease in the U.S. each year, and that 5 to 10% of those cases are fatal.

HOW DO THERMOSTATIC MIXING VALVES SOLVE THE CONFLICTING PROBLEMS OF BOTH SCALDING AND BACTERIA GROWTH?

Thermostatic mixing valves, by design, temper hot water from the water heater by mixing in cold water with the hot water from the heater and delivering water to the outlets at a safer temperature. While this prevents scalding, it also allows water in the water heater to be stored at a temperature high enough to prevent bacteria growth. All **Cash Acme Heatguard®** valves feature an adjustable temperature range that allows the end user to set the temperature of the water being distributed (maximum of 49°C [120°F]), which permits the water in the heater to be stored at a safe, sterile temperature.

HOW DOES A HEATGUARD® THERMOSTATIC MIXING VALVE WORK?

The **Cash Acme Heatguard® Thermostatic Mixing Valve** has a simple yet innovative design. The valve is controlled by continuous monitoring of the outlet temperature by a thermostatic element composed of encapsulated wax which automatically adjusts the mix ratio of hot and cold water according to the temperature setting on the valve. Hot water enters the valve, which causes the encapsulated wax to expand and drive the integrated piston upward, which allows the cold water supply to enter the valve, thus mixing the two water supplies. The **Cash Acme Heatguard®** valves also feature a shutdown safety in the case of cold water failure.

WHERE CAN MIXING VALVES BE INSTALLED?

There are two options when selecting where to install a mixing valve: (1) A master automatic mixing valve may be installed directly at the water heater. This is the simpler and more economic solution. (2) This option may be useful when it is desired to deliver water at different temperatures to each outlet (for example, higher temperature water to the dishwasher and clothes washer, or lower temperature water to a bidet). Please see options 1 and 2 on page 6.

Note: It is recommended that an automatic compensating shower valve be fitted in each shower fixture regardless of which option is selected. A shower valve will compensate for localized changes in supply pressures that may give rise to thermal shock conditions at the shower (e.g., a flushed toilet that "steals" some of the cold supply to the shower).

ARE THE PROBLEMS OF SCALDING AND BACTERIA GROWTH ONLY PRESENT IN RESIDENTIAL SETTINGS?

Commercial, as well as industrial, settings are also susceptible to these dangers. Outbreaks of Legionnaires' disease are very common in hotel and apartment settings. In fact, the disease got its name from an outbreak at a Philadelphia hotel that was hosting an American Legion convention in 1976. Scalding is also a prominent danger in commercial settings. Recently, a Florida man had to have 3 fingers amputated due to the lack of proper water heater maintenance at his apartment building (<http://www.contractormag.com/articles/newsarticle.cfm?newsid=386%20>). The man was awarded \$925,000 in a lawsuit against the landlord of the apartment building. Cash Acme offers a Masterguard® series of commercial/industrial mixing valves, ranging from 3/4" up to 2". The Masterguard® mixing valves are capable of servicing an entire building, as well as a section or floor of a building.

Maximum Hot Water Temperature

THE CHANGE

The National Research Council (NRC) Standing Committee on Building and Plumbing Services recently adopted a change to the Plumbing Code that requires water supplied by fittings in residential buildings to be limited to a maximum of 49°C (120°F). This requirement can be met either by a master mixing valve at the heater or by mixing valves fitted at each outlet. Setting the water heater to 49°C (120°F) is not deemed to be acceptable.

The anticipated wording for the Code is as follows:

2.10.7 Maximum Temperature of Hot Water

- (1) Except as provided in Sentence (2), the maximum temperature of hot water supplied by fittings to fixtures in residential occupancy shall not exceed 49°C.
- (2) Sentence (1) does not apply to hot water supplied to installed dishwashers or clothes washers.

A-2.10.7 Maximum Temperature of Hot Water

Hot water delivered at 60°C will severely burn human skin in 1 to 5 seconds. At 49°C, the time for a full thickness scald burn to occur is 10 minutes. Children, elderly persons and persons with disabilities are most at risk.

There are several ways of achieving the objective of Article 2.10.7. Automatic compensating mixing valves or other devices can be installed at each fixture or a master automatic compensating mixing valve can be used to meet the objective. These valves are adjustable and can be set to deliver water at a maximum set point.

Storing water at temperatures below 55°C in the hot water tank may lead to the survival and or growth of bacteria. This concern should be addressed in designing hot water delivery systems because the actual water temperature within the tank can vary from the thermostat setting. Precautions have to be taken to ensure that bacteria contamination of the hot water delivery system is minimized.

IMPLEMENTATION DATE

It is expected that the final approval for the code change will be obtained in early 2004 and that it will then be issued as an interim change. The change will then be implemented by mid 2004.

This change will be adopted only for new construction. However, it does not set the accepted best practice for water temperature control for all water heater installations.

REASONS FOR THE CHANGE

1. SCALDING

High water temperatures are dangerous! The higher the water temperature the shorter the time taken to scald. It is commonly accepted that water temperatures higher than 49°C (120°F) should not be available at outlets used for bathing purposes. At 49°C (120°F) it takes approximately 5 minutes to sustain a full thickness burn. An increase to only 55°C (131°F) dramatically reduces the time for a full thickness burn to less than 1 second in a child!

2. LEGIONELLA BACTERIA

This bacteria thrives in warm water environments (i.e. 49°C [120°F] or less), and is thus a potential problem in hot water distribution systems. Water stored at 49°C (120°F) or less can provide ideal conditions for the growth of Legionella bacteria within the water heater. It is necessary to store water at 60°C (140°F) or higher to minimize the bacteria growth.

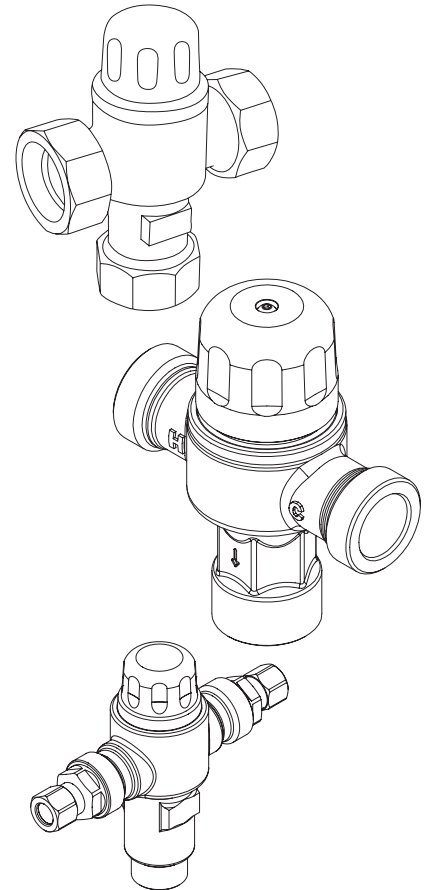

HEATGUARD®
THERMOSTATIC MIXING VALVES

COMPLYING WITH CODE

The Code suggests two methods of complying with the new requirement:

- (1) A master automatic compensating mixing valve installed at the water heater, or
- (2) Automatic compensating mixing valves or other devices installed at each fixture.

These valves are adjustable and can be set to deliver water at a maximum setting.

Option 1, the master mixing valve, is the simpler and more economical solution. A single valve fitted at the heater can control the water temperature to the whole installation.

Notes:

- (a) Regardless of which method of compliance is selected, it is recommended that an automatic compensating shower valve be fitted in each shower fixture. A shower valve will compensate for localized changes in supply pressures that may give rise to thermal shock conditions at the shower (e.g., a flushed toilet that "steals" some of the cold supply to the shower).
- (b) If desired, hot water can be supplied directly from the heater to dishwashers and clothes washers.

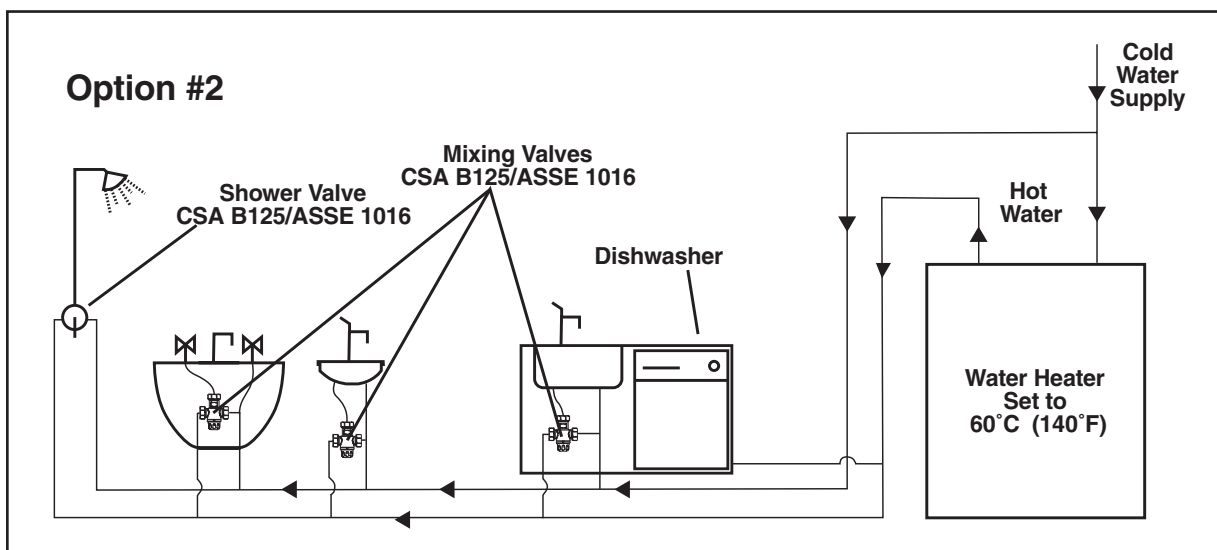
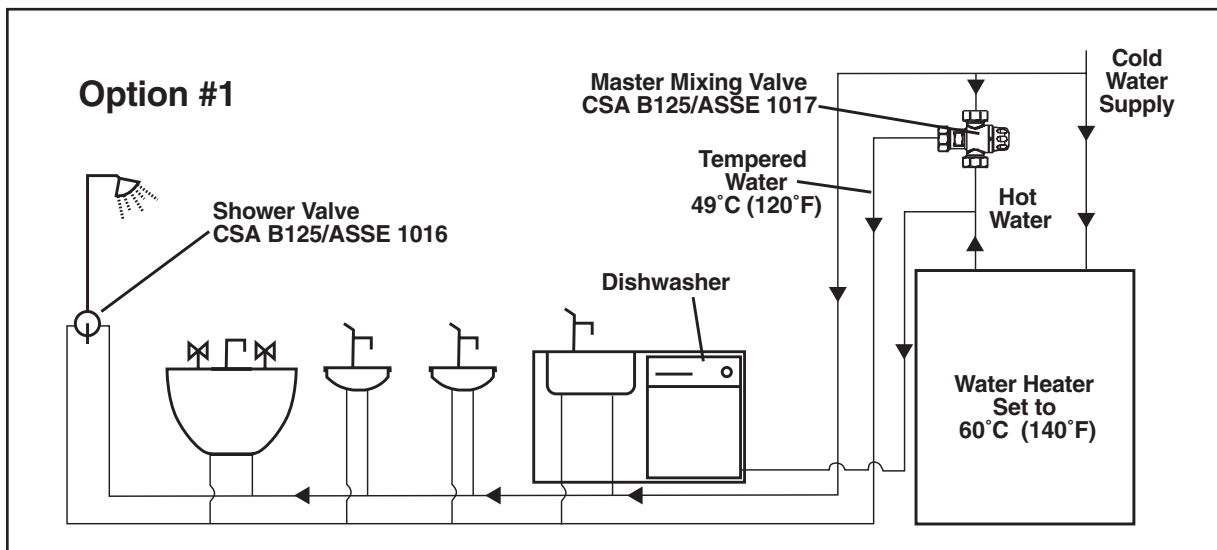

Heatguard® Series General Information



PRINCIPLE OF OPERATION

Thermostatic mixing valves are designed to mix hot and cold water supplies and deliver water at a safe, controlled temperature. The valve is controlled by continuous monitoring of the outlet temperature by a thermostatic element which automatically adjusts the mix ratio of hot and cold water according to the temperature setting of the valve. The Cash Acme Heatguard® valves also offer the additional protection of a shutdown in case of cold water failure.

APPLICATIONS

Distribution: The Cash Acme Heatguard® Thermostatic Mixing Valve allows a higher water temperature at the heating source to maintain peak efficiency and to prevent the formation of bacteria in domestic supplies. While the water at the heating source can be stored at a much higher temperature, the water is distributed at a safer temperature by the thermostatic mixing valve.

Point of Use: In larger distribution systems or in single purpose usage when water is maintained at elevated levels, a valve can be fitted at the point of use to reduce the outlet temperature at a hand lavatory, bath or other facility. Valves can also provide water at a safe controlled temperature, therefore reducing the risk of scalding and also the growth of *Legionella* bacteria.

MARKETS

Heating: The Cash Acme Heatguard® Series provides an accurate and inexpensive valve for hydronic heating system applications. These valves present outstanding characteristics including high flow rates and the lowest pressure drop with the widest temperature adjustment range available. Heatguard® also provides flexibility in installation with union fittings, a variety of tail pieces and offers a dummy valve for quick and sanitary installation. Heatguard® continues to be the preferred choice of informed contractors and designers.

Domestic/Potable Water: Heatguard® valves assist in the prevention of scalding with safe and reliable products. Since the bacteria *Legionella pneumophila* which causes Legionnaires' disease is able to live in 49°C (120°F) water, water heaters should be set to a minimum of 60°C (140°F). In domestic applications, the Heatguard® valve placed at the hot water heater can insure that the water delivered to the fixtures remains in the 49°C (120°F) range while providing higher temperatures to the dishwasher and other appliances. In commercial/institutional applications, a high temperature can be controlled at individual points by a local thermostatic mixing valve for the system (single faucet or multiple showers/sinks etc.)

INSTALLATION ISSUES:

Some installation issues are necessary to be considered when using thermostatics.

- For example: *Where can they be installed?*
How many outlets will the valves supply?
What type of fittings do I use?
Do I need check valves?

This section only deals with the most common application questions surrounding the installation of thermostatic mixing valves. However, the installer must be cognizant of local regulations. Please consult the factory for further information.

SITE CONDITION

Before the installation you must confirm that the site conditions are within the specified limits for the valve. In particular, check the hot and cold supply pressures and temperatures. Verify that site conditions are within the prescribed minimum and maximum operating factor of the valve.

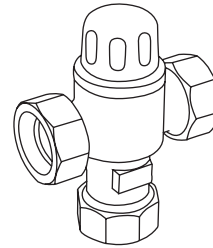

110-D

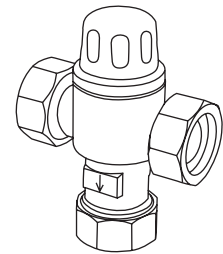

110-H

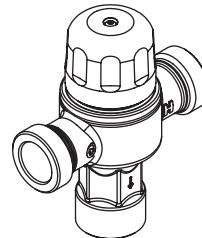

115-D

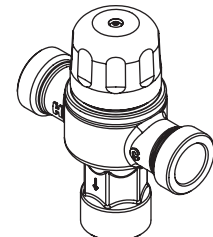

115-H

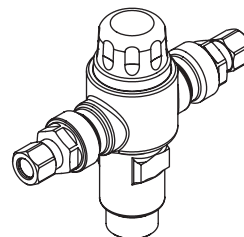

145

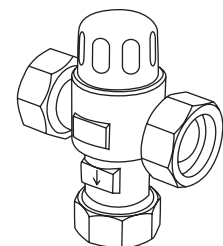

160

Heatguard® Series General Information



VALVE LOCATION

There is not one ideal location for all applications. It will vary from site to site. The most common location for installation is either at the water heater or directly at the fixture(s) to be serviced by the valve. However there are a number of considerations to make before choosing the best location for the valve installation. The most important consideration is compliance with the requirements of the application. Consideration must also be given by the installer to assure compliance with the codes and jurisdiction of the approvals.

In residential/domestic applications it is often preferable to install the valve at the hot water heater to protect the entire system. From the cost point of view this is the best location as the valve can be easily installed and serviced. In some installations it might be preferable to install a valve right at the washroom to be serviced, usually located under the hand lavatory or in an access door to permit future service of the valve.

COMMISSIONING

Each valve is tested and factory set. However, every valve must be commissioned on-site to take account of each particular installation's conditions. The valve can be commissioned by measuring the water temperature at the nearest outlet to the valve. A thermometer must be used so that an accurate measurement can be taken. Run the water until the temperature stabilizes. Adjust the valve as necessary, allowing the temperature to stabilize after each adjustment. Once the desired temperature has been reached, the installer must lock the valve into position using the locking tabs on the adjusting knob and locking ring or by protecting the adjuster by replacing the snap-on cover.

INSTALLATION PRECAUTION

Thermostatic mixing valves are temperature sensitive devices so they must not be subjected to extreme temperatures in use or installation. If using sweat fittings, do not solder with the main body of the valve. After flushing the system, install the actual valve and proceed with commissioning of the valve.

SERVICING

The function of the valve can be simply checked by measuring the temperature of the water at the outlet nearest the valve. If the temperature remains the same as the original commissioned temperature then the valve is functioning correctly. If the temperature has changed, it might be due to a build-up of debris in the strainers or the valve or a change in the supply conditions. The valve should be disassembled and checked for foreign materials inside and cleaned and a new temperature adjustment should be made. Please contact the factory for further servicing/trouble-shooting instructions at 1-888-820-0120.

FLOW RATES, VELOCITIES AND SUPPLY PRESSURES

All consideration of the system and its operation must be taken into account when selecting and installing a thermostatic mixing valve in a domestic system. While a single valve may be able to deliver sufficient amount of tempered water to supply two or more bathrooms, consideration must be given to all factors including: water velocity through the pipe, flow rate required at the furthest outlet, available pressure at the furthest outlet, lengths of branch outlets and fixture units requirements.

CASH ACME HEATGUARD® RECOMMENDATION

We have developed a range of thermostatic mixing valves suitable for most applications related to individual systems in residential, commercial and institutional. Our recommendation with regards to temperature requirements is simple in that, to assist in complying with Codes, Standards and Safe Practices, the installation of a thermostatic mixing valve will assure delivery of hot water at a safe temperature. Our valves are certified under the applicable Industry Standards and meet or exceed performance guidelines.

Do not hesitate to contact our offices for any inquiries.

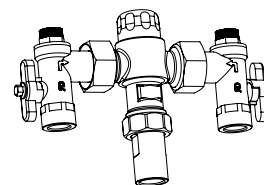

160 4 in 1

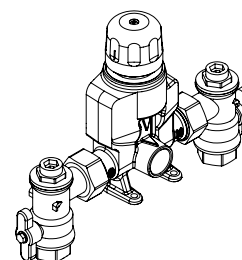

Masterguard

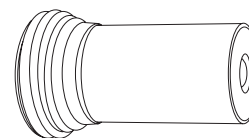

BathSafe 24109

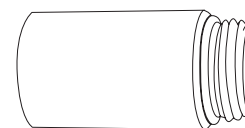

ShowerSafe 24110



TapSafe 24108

Heatguard® 110-D Series



DISTRIBUTION VALVE INSTALLED AT THE WATER HEATER (SINGLE FAMILY HOME)

The Heatguard® 110-D is intended for installation at the water heater to distribute controlled temperature water through a domestic hot water system. The valve delivers water at a maximum of 49°C (120°F), allowing the heater to be set at 60°C (140°F) or higher, thus providing a greater effective volume of hot water and reducing the chances of Legionellae bacteria growth in the water. Listed by ASSE (to ASSE 1017) and IAPMO (cUPC to ASSE 1017 and CSA B-125).

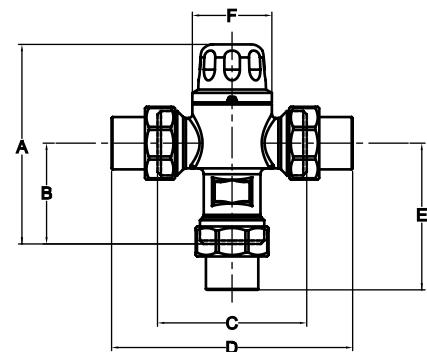
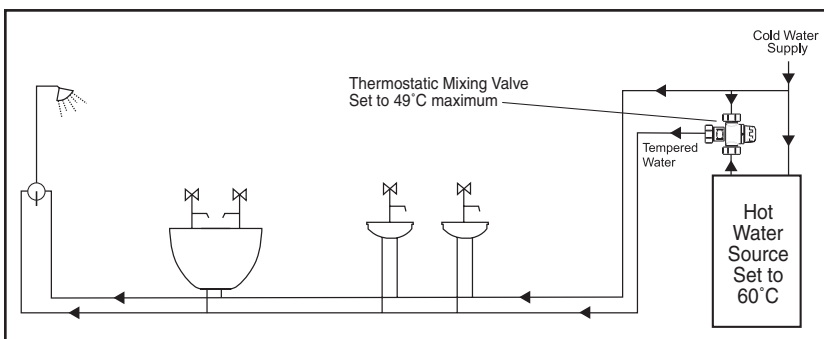
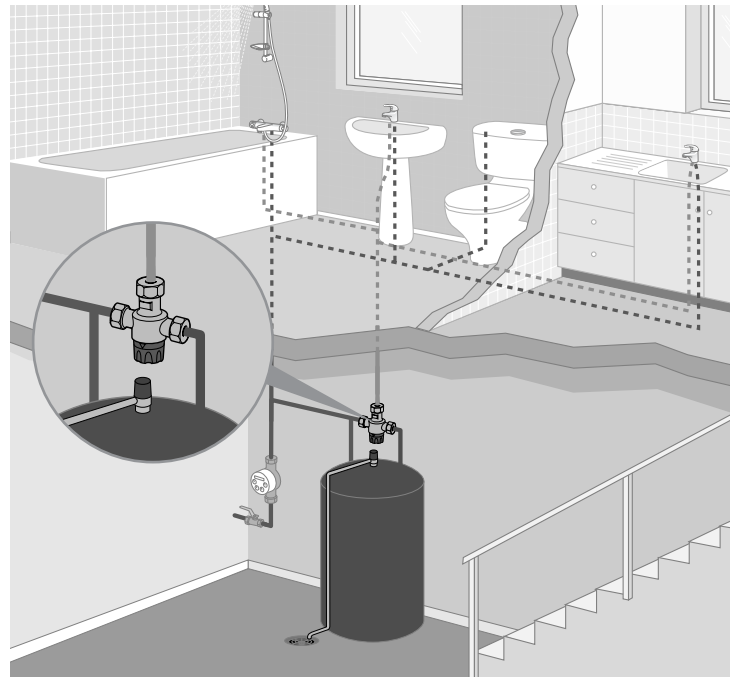

Dimensions	A	B	C	D	E	F
Base Valve	4.1 (103)	2.1 (52)	3.0 (76)	*	*	1.6 (41)

* Please Refer to Fittings Kits Spec. Sheet (CC001) for Dimensions.

SPECIFICATION DATA

Performance:

- Outlet temp. range 35 - 49°C (95 - 120°F)
- Temp. hot supply 90°C (195°F) max.
- Temp. cold supply 4 - 27°C (39 - 80°F)
- Temp. stability +/- 3°C (5°F)
- Working pressure Max. 1,000 kPa (145 psi)
- Flow rate, minimum 1.0 gpm
- Flow rate, maximum 20 gpm

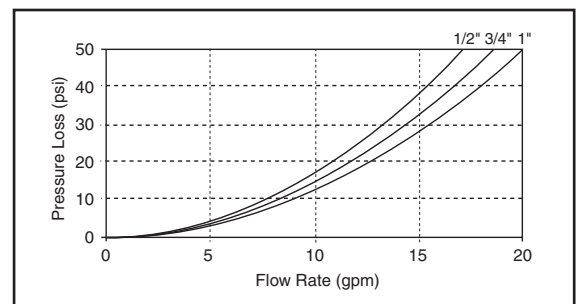

Heatguard® 115-D Series



DISTRIBUTION VALVE INSTALLED AT THE WATER HEATER (LARGE OR MULTI-FAMILY HOME)

The Heatguard® 115-D is intended for installation at the water heater to distribute controlled temperature water throughout a domestic hot water system. The valve delivers water at a maximum of 49°C (120°F), allowing the heater to be set at 60°C (140°F) or higher, thus providing a greater effective volume of hot water and reducing the chances of Legionella bacteria growth in the water. The valve flows 30 gpm at 45 psi, making it suitable for larger residential and commercial installations. Listed by ASSE (to ASSE 1017) and IAPMO (cUPC to ASSE 1017 and CSA B-125).

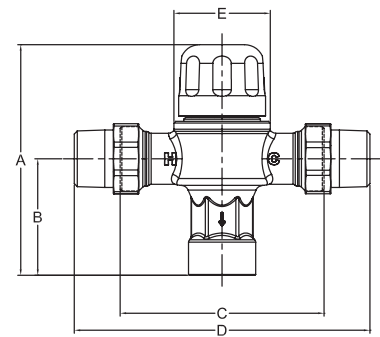
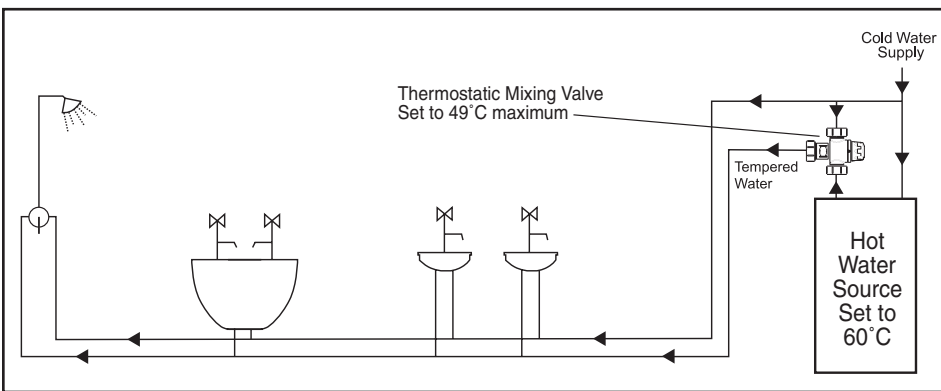
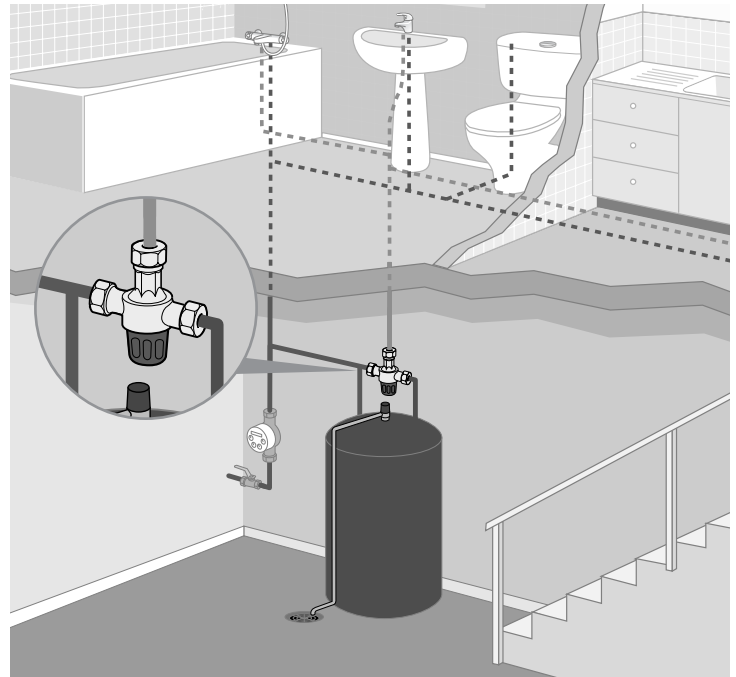

Dimensions	A	B	C	D	E
Base Valve	4,3 (108)	2,0 (50)	3,0 (76)	*	2,7 (68)
3/4" Sweat	4,3 (108)	2,0 (50)	3,0 (76)	6,6 (168)	2,7 (68)
1" Sweat	4,3 (108)	2,0 (50)	3,0 (76)	8,9 (227)	2,9 (74)
3/4" Threaded	4,3 (108)	2,0 (50)	3,0 (76)	8,2 (209)	4,1 (104)

Inches (mm)

* Please Refer to Fittings Kits Spec. Sheet (CA005) for Dimensions.

SPECIFICATION DATA

Performance:

- Outlet temp. range 35 - 49°C (95 - 120°F)
- Temp. hot supply 90°C (195°F) max
- Temp. cold supply 4 - 27°C (40 - 80°F)
- Temp. stability +/- 1.7°C (3°F)
- Working pressure, maximum ... 1,000 kPa (145 psi)
- Flow rate, minimum 2.5 gpm (10 L/min)
- Flow rate, maximum 50 gpm (190 L/min)

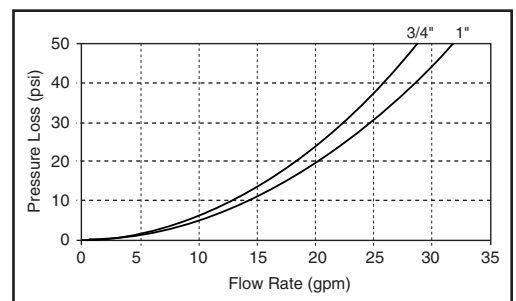

Heatguard® 145 Series



POINT-OF-USE (SINGLE FIXTURE)

The Heatguard® 145 is a compact Thermostatic Mixing Valve that mixes hot water with cold to deliver tempered water at a constant temperature. The Heatguard® 145 is specifically intended for use in conjunction with individual faucets and electronic sensor faucets. Listed by ASSE (to ASSE 1016) and by IAPMO (cUPC to ASSE 1016 and CSA B-125).

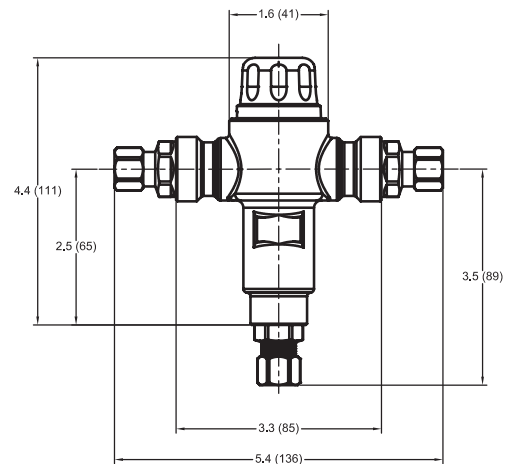

SPECIFICATION DATA

Performance:

- Outlet temp. range 35 - 46°C (95 - 115°F)
- Temp. hot supply 90°C (195°F) max.
- Temp. cold supply 4 - 27°C (39 - 80°F)
- Temp. stability +/- 1.7°C (3°F)
- Working pressure Max. 1,000 kPa (145 psi)
- Flow rate, minimum 0.5 gpm (2 L/min)
- Flow rate, maximum 5.5 gpm (21 L/min)

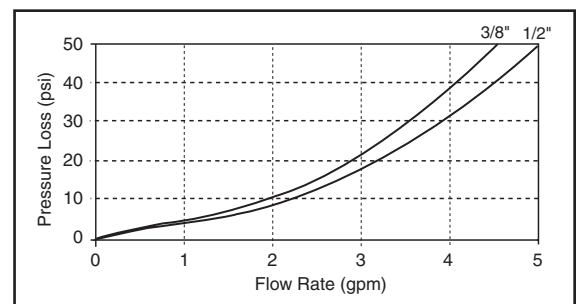

Heatguard® 160 4in1 Series



POINT-OF-USE (MULTIPLE OR SINGLE FIXTURE)

The Heatguard® 160 4in1 is a superior performance Thermostatic Mixing Valve that mixes hot water with cold to deliver tempered water at a constant temperature. The Heatguard® 160 4in1 is intended to supply controlled temperature hot water to any outlet requiring a higher level of protection, such as a tub or basin in a nursing home or lavatory faucets in a public place. Listed by ASSE (to ASSE 1016) and by IAPMO (cUPC to ASSE 1016 and CSA B-125).

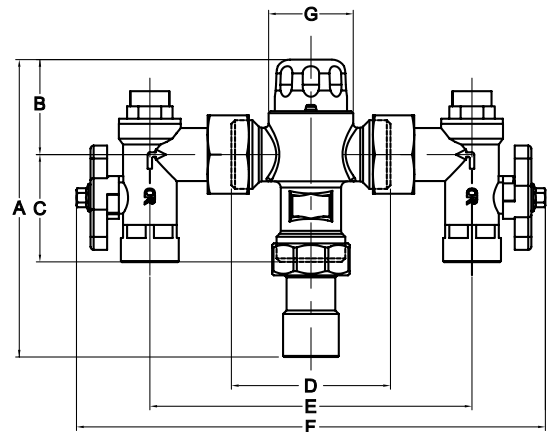
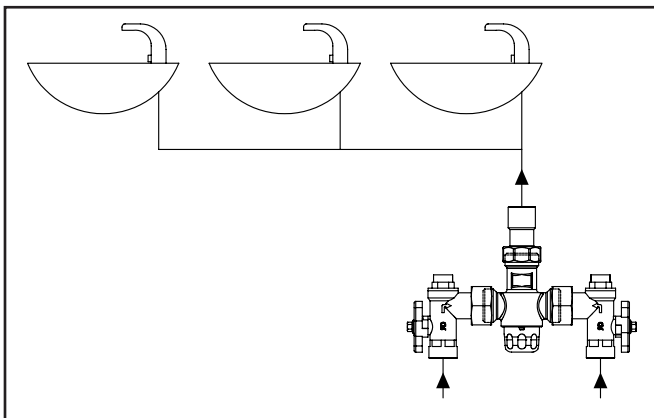
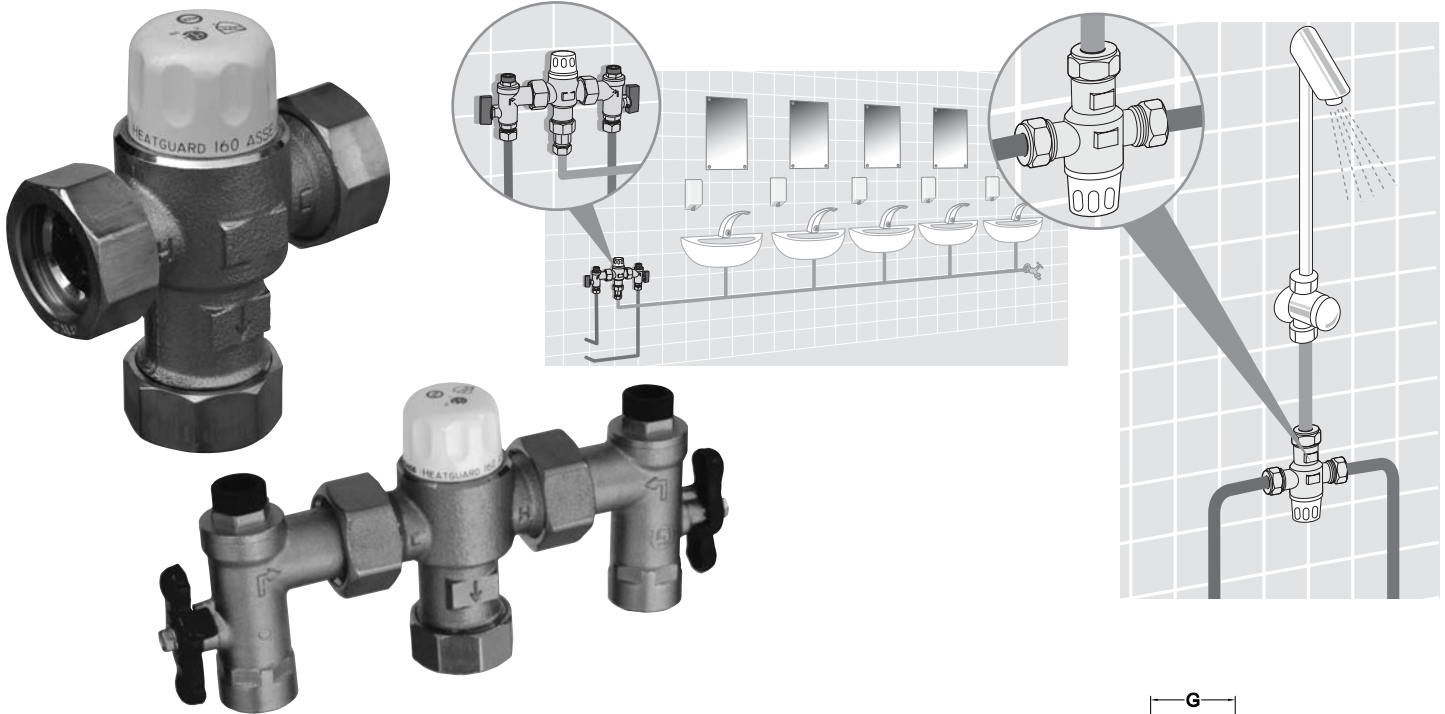

Dimensions	A	B	C	D	E	F	G
Base Valve	5.7 (144)	1.8 (46)	2.0 (52)	3.0 (76)	6.1 (156)	8.9 (227)	1.6 (41)

SPECIFICATION DATA

Performance:

- Outlet temp. range35 - 46°C (95 - 115°F)
- Temp. hot supply90°C (195°F) max.
- Temp. cold supply4 - 27°C (40 - 80°F)
- Temp. stability+/- 1.7°C (3°F)
- Working pressureMax. 1,000 kPa (145 psi)
- Flow rate, minimum0.5 gpm (2 L/min)
- Flow rate, maximum11 gpm (42 L/min)

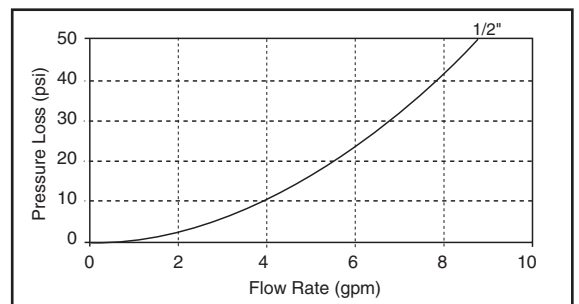

Masterguard® 800 Series



MIXING VALVE INSTALLED FOR COMMERCIAL AND INDUSTRIAL FACILITIES

The Masterguard® Series is a range of six high flow rate Temperature Actuated Mixing Valves from 3/4" to 2" that mix hot water with cold to deliver tempered water at a controlled temperature, typically 49°C (120°F) maximum. The Masterguards® are central mixers intended for installation in the plant room of commercial and industrial facilities to distribute controlled temperature water to the domestic hot water system of a whole building or a whole section of a building. Listed by ASSE (to ASSE 1017) and IAPMO (cUPC to ASSE 1017 and CSA B-125).

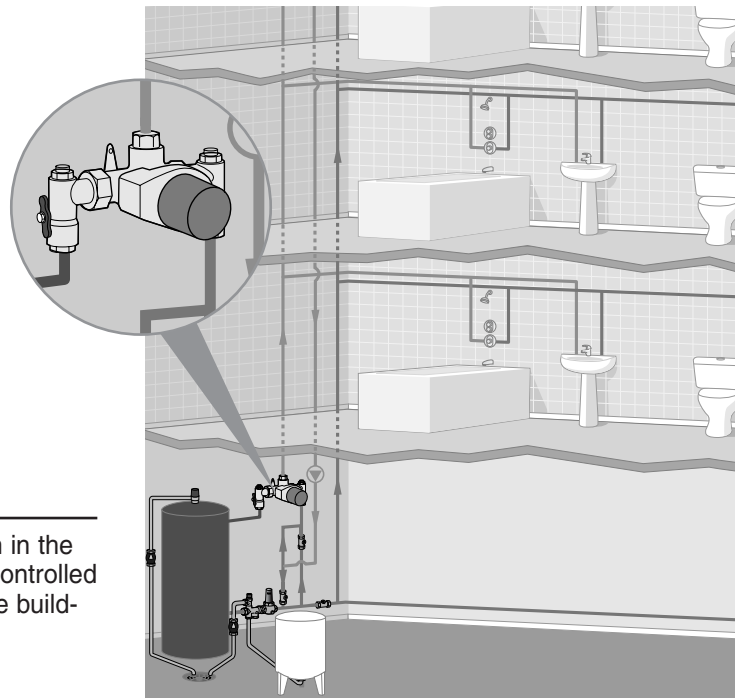
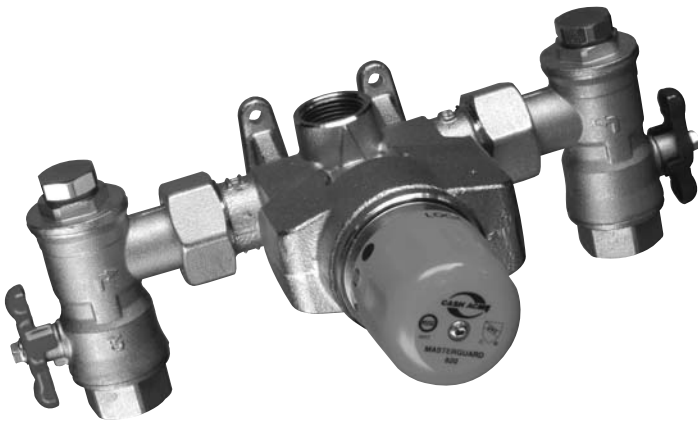

TYPICAL INSTALLATION

The Masterguards® are central mixers intended for installation in the plant room of commercial and industrial facilities to distribute controlled temperature water to the domestic hot water system of a whole building or a whole section of a building.

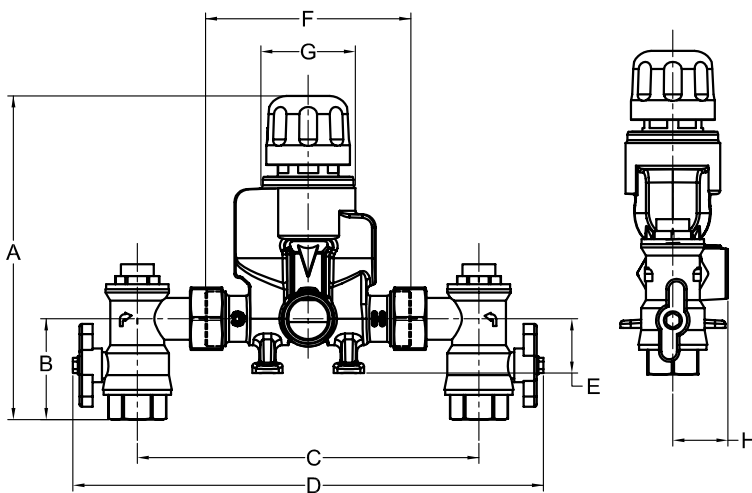

Performance:

- Outlet temp. range 35 - 49°C (95 - 120°F)
- Temp. hot supply 90°C (195°F) max.
- Temp. cold supply 4 - 27°C (40 - 80°F)
- Temp. stability +/- 3°C (5°F)
- Working pressure Max. 1,000 kPa (145 psi)

SPECIFICATION DATA

Measurement in inches

Product	Inlet	Outlet	Flow at 45 psi	Min Flow rate	A	B	C	D	E	F	G	H
810	1/2"	3/4"	19 gpm	1 gpm	5.5	2.2	7.1	9.8	1.2	3.9	2.0	1.1
820	3/4"	3/4"	30 gpm	2.5 gpm	6.7	2.4	8.1	11.3	1.3	4.9	2.4	1.3
830	3/4"	1"	51 gpm	4 gpm	9.2	2.4	10.0	13.1	1.7	6.7	3.5	1.9
840	1"	1 1/4"	75 gpm	8 gpm	10.2	2.8	10.2	13.6	1.7	6.5	3.5	1.9
850	1 1/4"	1 1/2"	105 gpm	13 gpm	11.5	2.5	13.7	16.3	1.9	9.3	5.1	1.9
860	1 1/2"	2"	149 gpm	18.5 gpm	11.5	2.5	13.7	16.3	1.9	9.3	5.1	1.9

Heatguard® Fittings and Accessories



DESCRIPTION

The Heatguard® Fitting Kits are for use with the Heatguard® 110 and 160 Series Mixing Valves.

The base Heatguard® Mixing Valves are furnished with three union nuts and face seals. The Heatguard® Fitting Kits contain three fittings of the selected type, to be used in conjunction with the base valve and union nuts.

FITTING KITS

Available Models	3/8"	1/2"	3/4"	1"
Sweat	N/A	24036	24037	24038
Sweat w/ check	N/A	24039	24040	N/A
Barb for PEX	N/A	24041	24042	24043
Barb w/ check	N/A	24044	24045	24046
Compression	N/A	24048	24049	N/A
Comp. w/ check	24051	24052	24053	24054
Threaded (NPT)	N/A	24055	24056	N/A
Threaded (NPT) w/ check	N/A	24057	24058	N/A
CPVC	N/A	24059	24150	N/A
CPVC w/ check	N/A	24060	24151	N/A

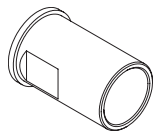

Sweat

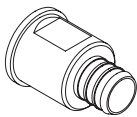

Barb

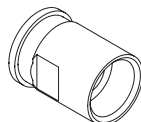

Compression

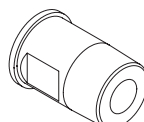

Threaded

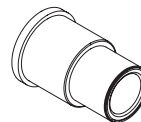

CPVC

SERVICE FITTING "4IN1"

Item No. 24061

- Isolating valve
- Non return check
- Mesh strainer
- Gauge port (1/4")
(gauge not included)

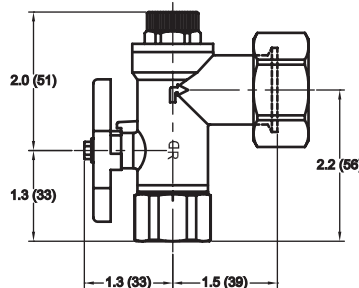

DUMMY VALVE

Item No. 25015

- Dummy valve
- Easy installation
- Easy flushing of system
- Cost saving installation
- Reduced inventory

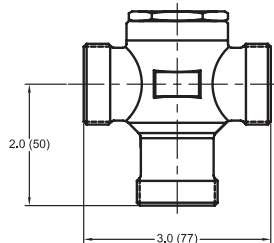

Thermostatic Mixing Valves



PRODUCT FEATURES

- ISO 9001 Certified Manufacturing Facility
- Fully certified: ASSE and IAPMO (cUPC)
- 100% factory tested
- Accurate temperature delivery
- Shut down on cold water failure
- Adjustable and lockable
- Set and locked in factory
- Integral unions
- Variable connections:
 - sweat, compression, barb, threaded, CPVC, 4 in 1
- Optional check valves
- Dummy valves for ease of installation
- High flow rates
- Low pressure drop
- Anti scaling polysulfone piston
- Pressure imbalance stability
- Total Package
 - Distribution - ASSE 1017/CSA B-125
 - Point of Use - ASSE 1016/CSA B-125
 - End of Line - ASSE 1062
- Superior reliability
- Absolute temperature stability
- Robust low complexity construction
- Easily serviced

**Over 50 years of experience
and 2 million valves sold.**

Troubleshooting Guide

FAULT/SYMPTOM	CAUSE	RECTIFICATION
1. The desired mixed water temperature cannot be obtained or valve is difficult to set.	<ul style="list-style-type: none"> • Hot and cold supplies are reversed. • Valve contains debris. • Strainers contain debris. 	<ul style="list-style-type: none"> • Refit the valve with Hot/Cold supplies fitted to the correct connections. • Flush water through valve. • Clean strainers ensuring debris is removed.
2. Mix temperature unstable.	<ul style="list-style-type: none"> • Strainers are fouled. • Fluctuating supply pressures. 	<ul style="list-style-type: none"> • Clean strainers. • Install pressure reducing valves on hot and cold supplies.
3. Mix temperature changing over time.	<ul style="list-style-type: none"> • Fluctuating supply pressures. • Strainers contain debris. 	<ul style="list-style-type: none"> • Install pressure reducing valves. • Clean strainers ensuring debris is removed.
4. Either full hot or full cold water flowing from outlet fixture.	<ul style="list-style-type: none"> • Valve is incorrectly set. • Hot/Cold water had migrated to other inlet. Refer also to point 1. 	<ul style="list-style-type: none"> • Adjust mix temperature. • Check non-return valve is not fouled. Clean if necessary.
5. No flow from the valve outlet.	<ul style="list-style-type: none"> • Hot or cold water supply failure. • Strainers are fouled. 	<ul style="list-style-type: none"> • Restore inlet supplies and check mix temperature. • Clean strainers.
6. Flow rate reduced or fluctuating.	<ul style="list-style-type: none"> • Valve or inlet fittings fouled by debris. • Fluctuating supply pressures. 	<ul style="list-style-type: none"> • Check valve and inlet fittings for blockages. • Clean or flush as necessary. • Install pressure reducing valves.
7. Mixed water temperature too hot or cold.	<ul style="list-style-type: none"> • Valve has been tampered with. • Valve incorrectly set. • Inlet temperatures are not within specified limits. 	<ul style="list-style-type: none"> • Readjust valve to required set temperature. • Ensure inlet temperatures are within the specified limits for the valve.
8. Mixed water temperature does not change when the temperature adjuster is altered.	<ul style="list-style-type: none"> • Hot and cold supplies are reversed. 	<ul style="list-style-type: none"> • Refit the valve with Hot/Cold supplies fitted to the correct connections.
9. Hot water flows into the cold water system or vice versa.	<ul style="list-style-type: none"> • Check valves fouled. 	<ul style="list-style-type: none"> • Clean strainers ensuring debris is removed.
10. Valve is noisy.	<ul style="list-style-type: none"> • Water velocity above velocity requirements. 	<ul style="list-style-type: none"> • Reduce water velocity.



OVERBUILT IS AN UNDERSTATEMENT.™

Cash Acme Canada • 1-888-820-0120 • FAX: 1-888-820-0121 • www.cashacme.ca

A Division of the Reliance Worldwide Corporation 

The RWC logo consists of the letters "RWC" in a bold, sans-serif font, with a small ".com" to the right. The text is enclosed within an oval shape that has a globe-like texture, suggesting a worldwide presence.