

HEATGUARD™

THERMOSTATIC MIXING VALVES

THE PROBLEM

1. SCALDING

High water temperatures are dangerous! The higher the water temperature the shorter the time taken to scald. It is commonly accepted that water temperatures higher than 120°F (49°C) should not be available at outlets used for bathing purposes. At 120°F (49°C) it takes approximately 5 minutes to sustain a full thickness burn. An increase to only 130°F (54°C) dramatically reduces the time for a full thickness burn to less than 1 second in a child!

2. LEGIONELLA BACTERIA

This bacteria thrives in warm water environments (i.e. 120°F [49°C] or less), and is thus a potential problem in hot water distribution systems. Water stored at 120°F (49°C) or less can provide ideal conditions for the growth of legionella bacteria within the water heater. It is necessary to store water at 140°F (60°C) or higher to minimize the bacteria growth.

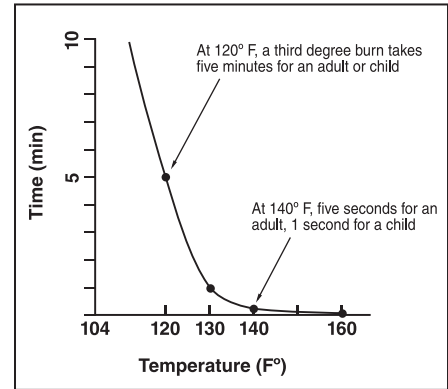

So, how can these two apparently conflicting problems be overcome...

THE SOLUTION

The Cash Acme Heatguard® thermostatic mixing valve!

A Heatguard® mixing valve installed at the water heater is able to deliver hot water at a safer temperature of 120°F (49°C). The heater can then be set at 140°F (60°C), thus reducing the chances of legionella bacteria growth within the system. A Heatguard® valve can protect the whole system by delivering controlled temperature hot water to all outlets.

“Heatguard®” The Product

Reliance is the worldwide market leader in the manufacture of under counter / small distribution thermostatic mixing valves. Now a part of Reliance, Cash Acme offers the proven reliability of more than 2,500,000 successful installations worldwide. Our experience over the last 50 years in the manufacture and distribution of safety valves for residential, commercial and industrial markets has led to the development of a complete range of valves to provide safe water temperature.

Principle of Operation

Thermostatic valves are designed to mix hot water with cold water to deliver mixed water at a safe, controlled temperature. The valves incorporate a thermostatic element that continuously senses the mixed water temperature and adjusts the piston position which in turn regulates the proportion of incoming hot and cold water. In doing so the valve is able to maintain a constant outlet temperature. The Cash Acme Heatguard® valves also offer the additional protection of “shut-down” in the event of a failure of either the hot or cold water supply. The Heatguard® valves can be adjusted through a range of temperatures to suit the particular application.

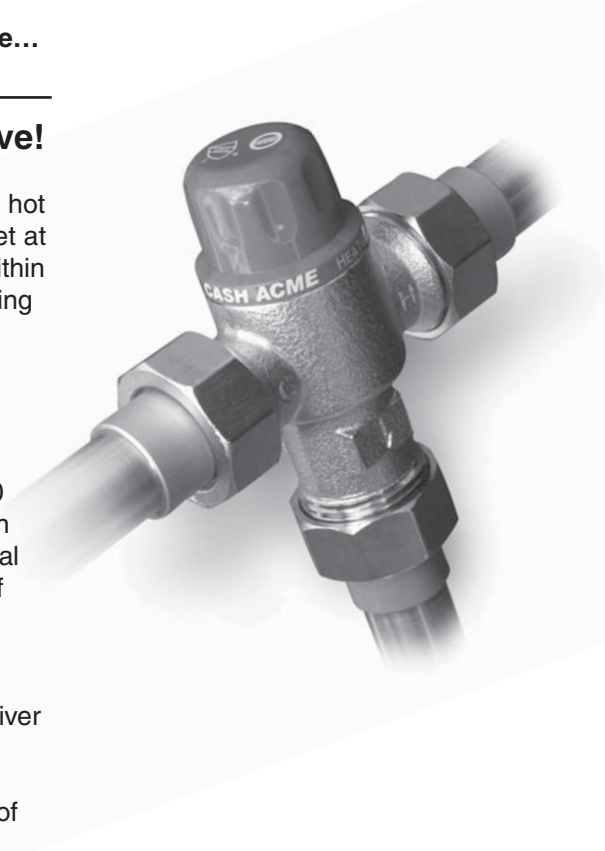

HEATGUARD® APPLICATIONS:

DISTRIBUTION: HEATGUARD 110-D

The Cash Acme **Heatguard®** 110-D thermostatic mixing valve is designed to be fitted at the water heater, to distribute water at a maximum of 120°F (49°C) to all bathing areas, thus minimizing the risk of scalding. The installation of the **Heatguard®** 110-D mixing valve at the water heater also allows the heater to be set to a higher temperature. A higher thermostat setting allows more efficient operation and delivery of hot water from the water heater, and in doing so increases the effective volume of hot water from that heater. Furthermore, storing water at 140°F (60°C) minimizes the growth of legionella bacteria within the water heater. The latest information indicates that Legionnaires' disease, caused by the legionella bacteria, is a grossly under diagnosed condition with similar symptoms to pneumonia. This bacteria enjoys warm water environments, and is thus a potential problem in hot water distribution systems. A water temperature of 120°F (49°C) or less can provide conditions that allow legionella to thrive. Increasing the stored water temperature to 140°F (60°C) kills the majority of the legionella bacteria and greatly reduces the chances of an unsafe water supply.

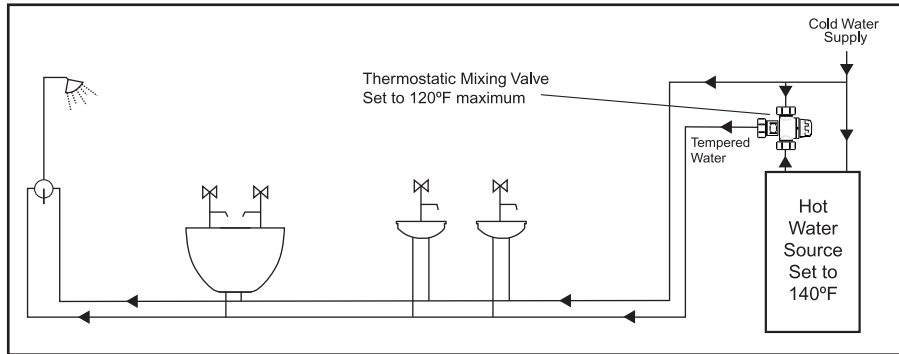

HEATING: HEATGUARD® 110-HX

The Cash Acme **Heatguard®** H Series is an accurate and inexpensive control for use in hydronic and radiant heating applications. The valve offers outstanding characteristics including high flow rate / low pressure loss and a wide temperature adjustment range. The **Heatguard®** H Series also provides installation flexibility with union fittings and a range of tail pieces. There is also a “dummy valve” to assist in flushing the system after installation but prior to commissioning. The **Heatguard®** H Series continues to be the preferred choice of informed contractors and designers.

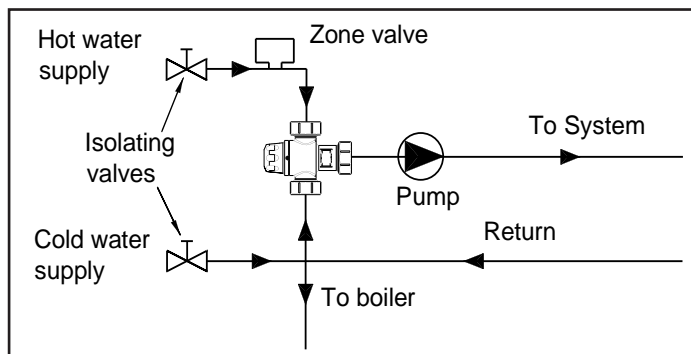

POINT-OF-USE: HEATGUARD® 160 & 145

In larger distribution systems, or in grouped applications where the hot water supply is at an elevated temperature, a Cash Acme **Heatguard®** 160 or 145 can be fitted at the point-of-use to reduce the outlet temperature. The most common applications are single or grouped hand washing basins, although the valves can also be used to deliver controlled hot water to the tubs and showers. The **Heatguard®** 145 can also be used in conjunction with electronic sensor faucets to deliver safe water temperature, and to assist in meeting ADA requirements.

