

Cash Acme™

EB25 Pressure Regulating Valve

The patented EB25 single cartridge design is optimal for delivering steady flow even with extreme variations in supply pressure. With fewer parts, the ease of serviceability and increased reliability make this valve the most advanced on the market. The innovative “micro-finger” design eliminates the water whistle associated with other pressure regulating valves by dissipating noise as water flows across the seat.

Approved Applications

Commercial and domestic water applications.

Specification Data

Performance

Inlet pressure	300 psi
Temperature range	33°F - 180°F (0.6°C - 82.2°C)
Service	Water
Outlet pressure range	20-90 psi

Materials

Body	Lead-Free ¹ Brass or Stainless Steel
Spring Chamber	Nylon
Adjusting Spring	Steel (Zinc Plated)
Diaphragm	Reinforced EPDM
Body Seat	Polysulfone
Seat Disc	EPDM
Piston	Stainless Steel
Strainer Screen	Stainless steel
Pressure Plate	Steel (Zinc Plated)

SharkBite Union Materials

Body	Lead-Free ¹ DZR Brass
O-ring	EPDM
Grab Ring	Stainless-Steel Tube Support
Liner	Polysulfone

¹ Lead free for all models. Surfaces that are in contact with consumable water contain less than 0.25% lead by weight.

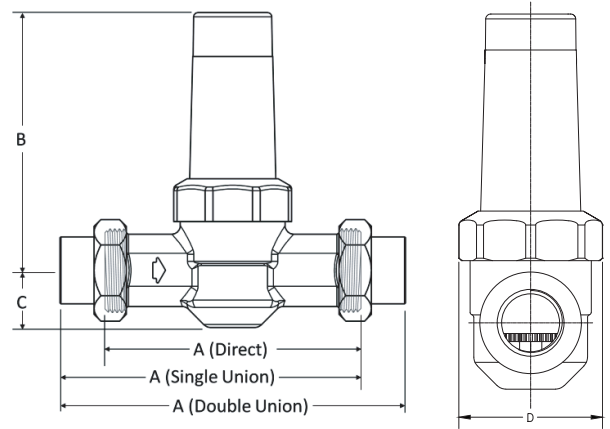

EB25 Bronze Body Dimensions (inches)

Size	Connection Style	A			B	C	D
		Direct	Single Union	Double Union			
1/2"	NPT	-	5-49/64	-	4-59/64	1-1/16	2-9/32
	Sweat	-	5-9/16	-	4-59/64	1-1/16	2-9/32
	Cold Expansion	-	-	5-35/64	4-3/8	3/4	2-9/32
3/4"	NPT	4-7/8	4-1/2	6-11/16	4-59/64	1-1/16	2-9/32
	Sweat	-	4-21/32	6-11/16	4-59/64	1-1/16	2-9/32
	Barb	-	-	7-3/32	4-59/64	1-1/16	2-9/32
	Cold Expansion	-	-	6-3/32	4-3/8	3/4	2-9/32
	SharkBite	-	-	8-7/16	4-59/64	1-1/16	2-9/32
	Copper Press	-	-	6-3/10	4-59/64	1-1/16	2-9/32
1"	NPT	4-7/8	5-23/32	6-51/64	4-59/64	1-1/16	2-9/32
	Sweat	-	5-27/32	7-3/64	4-59/64	1-1/16	2-9/32
	Barb	-	-	7-19/32	4-59/64	1-1/16	2-9/32
	Cold Expansion	-	-	7-7/16	4-11/32	1-3/64	2-9/32
	SharkBite	-	-	9-11/34	4-59/64	1-1/16	2-9/32
	Copper Press	-	-	6-1/3	4-59/64	1-1/16	2-9/32
1-1/4"	NPT	-	5-11/16	6-35/64	7-31/64	1-13/32	3-7/64
	Sweat	-	5-7/8	6-15/16	7-31/64	1-13/32	3-7/64
	Cold Expansion	-	-	8-25/64	7-31/64	1-13/32	3-7/64
	SharkBite	-	-	8-23/32	7-31/64	1-13/32	3-7/64
1-1/2"	Copper Press	-	-	6-1/2	7-31/64	1-13/32	3-7/64
	NPT	-	5-29/32	7	7-31/64	1-5/8	3-5/32
	Sweat	-	6	7-11/64	7-31/64	1-5/8	3-5/32
	Cold Expansion	-	-	9-5/32	7-31/64	1-5/8	3-5/32
	SharkBite	-	-	9-1/16	7-31/64	1-5/8	3-5/32
	Copper Press	-	-	6-13/16	7-31/64	1-5/8	3-5/32
2"	NPT	-	6	7-3/16	7-31/64	1-57/64	3-11/16
	Sweat	-	6-1/4	7-11/16	7-31/64	1-57/64	3-11/16
	Cold Expansion	-	-	10-1/64	7-31/64	1-57/64	3-11/16
	SharkBite	-	-	9-11/34	7-31/64	1-57/64	3-11/16
Copper Press	-	-	6-61/64	7-31/64	1-57/64	3-11/16	

Cash Acme EB25 Flow Capacity

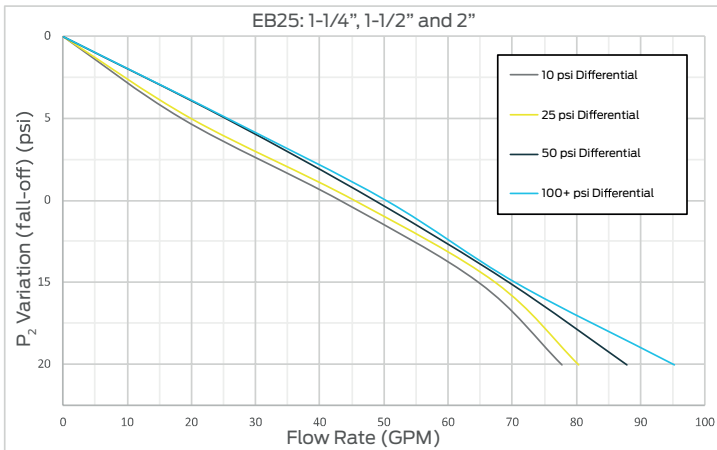
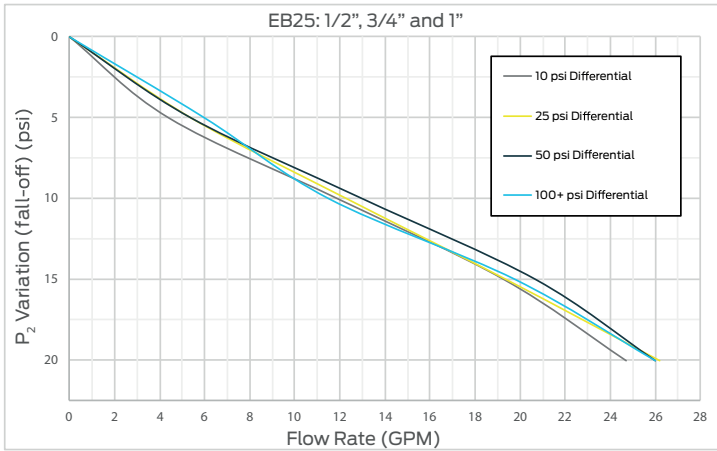

Pressure Differential: Difference between the inlet pressure and the PRV set pressure.

P₂ Variation: Pressure reduction of the outlet due to the demand created downstream when a fixture is opened and water is allowed to flow through the PRV.

Certifications & Listings

ASSE 1003, CSA B356, NSF/ANSI/CAN 372,
NSF/ANSI/CAN 61
Refer to local plumbing code

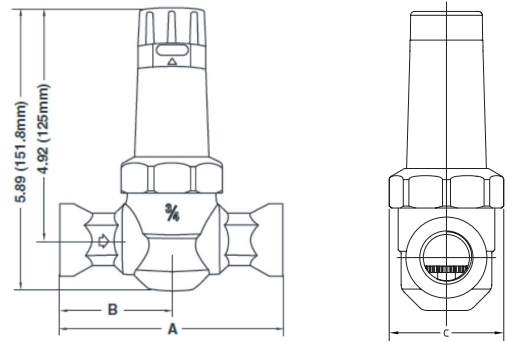

EB25 Stainless-Steel Body Dimensions (inches)

Size	Connection Style	A	B	C
3/4"	NPT (Both ends)	4-7/8	2-7/16	2-9/32
3/4"	Double Union NPT	6-11/16	3-3/8	2-9/32
1"	NPT (Both ends)	4-7/8	2-7/16	2-9/32
1"	Double Union NPT	6-13/16	3-7/16	2-9/32

Cash Acme PRV Cavitation Chart

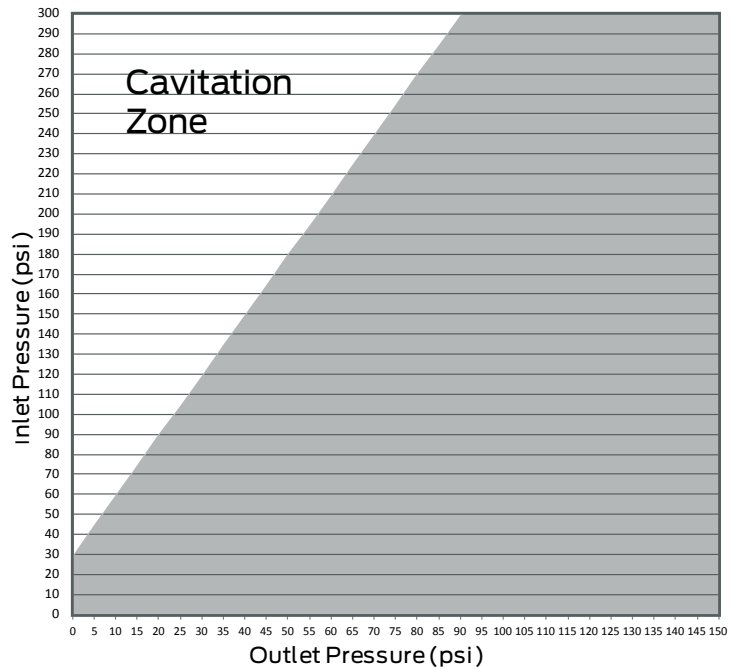

Product Submittal

Name	
Date	
Architect/Owner	
Contractor	
Tag	
Notes	