

Cash Acme®

FWL-2F and FWL-2

Pressure-Only Safety Relief Valve

The Cash Acme FWL-2F and FWL-2 are pressure only safety relief valves designed specifically for the protection of hot water supply systems where over-pressure conditions are likely to occur as a result of thermal expansion. Completely automatic, they reseal after pressure relief. The valve may be installed directly on the tank or in a tee and is appropriate for either side (hot or cold) of the water heater. Available in 1/2 in. (FWL-2 only) and 3/4 in. sizes with a male inlet and female outlet. The standard factory relief setting is 150 psi (75 and 125 psi also available). They are fitted with an all bronze body, brass and stainless steel internal parts, a silicone seat disc, and a stainless steel pressure spring. The FWL-2F and 3/4 in. FWL-2 are Lead-Free*.

Applications

Commercial and domestic hot water heating applications.

Specifications Data

Materials	
Body	Bronze
Seat Disc	Silicone
Internal Parts	Brass and Stainless Steel
Pressure Spring	Stainless Steel
Performance	
Inlet Pressure	150 psi (75 and 125 available)
Temperature Range	33°F - 250°F (0.6°C- 121.1°C)
Service	Water

*Lead Free available in the FWL-2F and 3/4 in. FWL-2. Surfaces that are in contact with consumable water contain less than 0.25% lead by weight.

Certifications & Listings

ANSI Z21.22/CSA 4.4
 Certified to ASME Boiler and Pressure Vessel Code Section XIII for Section IV (HV Designator) applications (see Rating Table).

Lead Free Valves are CSA certified to NSF/ANSI/CAN 372.

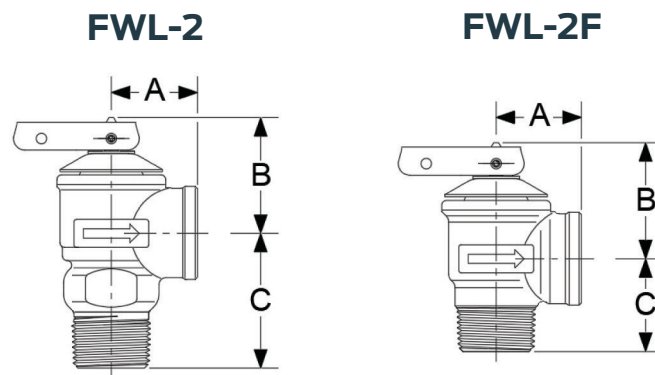

Dimensions (Inches)				
Type	Size	A	B	C
FWL-2F	3/4 in.	1-5/32 in.	1-9/16 in.	1-1/4 in.
FWL-2	1/2 in.	1-3/32 in.	1-9/16 in.	1-25/32 in.
FWL-2	3/4 in.	1-5/32 in.	1-9/16 in.	1-25/32 in.

Typical Installation

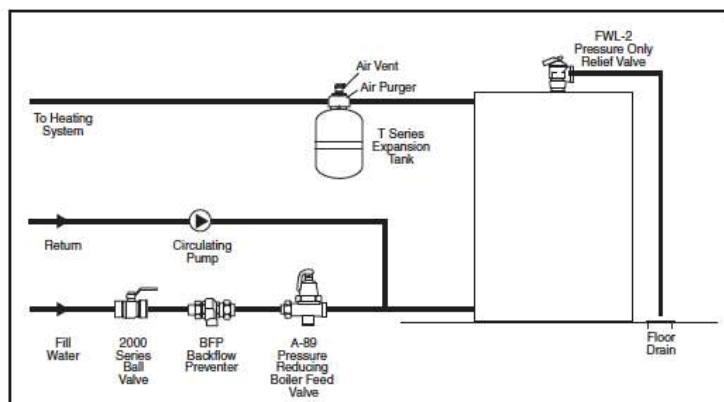

CSA (ANSI Z21.22/CSA 4.4) and ASME (Boiler Code Section IV) Ratings					
Type	Size (NPS)	CSA Rating (BTU/hr)	ASME Rating at Pressure Setting Indicated		
			75 psig (BTU/hr)	75 psig (BTU/hr)	75 psig (BTU/hr)
FWL-2F	3/4 in.	200,000 (1)	629,000	985,000	1,163,000
FWL-2	1/2 in.	15,000 (1)	N/R	N/R	N/R
FWL-2	3/4 in.	200,000(1)	629,000	985,000	1,163,000

(1) The 1/2 in and 3/4 in. FWL-2 at 75 psig are not CSA or ASME rated.
 (2) N/R indicates Type is available but Not ASME Rated.

Product Submittal	
Name	
Date	
Architect/Owner	
Contractor	
Tag	
Notes	